

Title: **Technical Specification for Hunter Vision System**

Total Pages: **80**

	Prepared By:	Vetted By:	Approved By:
Name	Marcus Tan	Roger Yeo	Steve Wah
Signature			
Appointment	Design Engineer	Head of Vetronics System Center	Project Chief Engineer
Date	2021/08/18	2021/08/19	2021/08/20

Revision Record				
Rev No.	Date Revised	Page(s) affected	Change Description	Reason(s) for Change
A	2021/08/18	-	New Release	

Revision Instructions

1. Method of revision will be through the issue of new document.
2. Revision No. will be advanced by one letter.
3. Change Description and Reason(s) for Change to be recorded.

CO_CONFIDENTIAL

CONTENTS

1	INTRODUCTION.....	5
2	OBJECTIVE	6
3	REFERENCES.....	7
4	DEFINITIONS	8
5	TECHNICAL SPECIFICATIONS	9
5.1	Design References	9
5.2	Product Quality Requirement	9
5.2.1	General Quality Requirements (GQR).....	9
5.2.1.3	Workmanship Standard.....	10
5.3	Design Quality Requirement	12
5.3.1	System Architecture.....	12
5.3.2	Video Server.....	13
5.3.2.1	General Requirements	13
5.3.2.2	Video Interface	15
5.3.2.3	Control Interfaces for Automatic View Change	17
5.3.2.4	Operating Power	19
5.3.2.5	Synchronization Feature.....	19
5.3.2.6	Video and Audio Recorder	19
5.3.2.7	Data Distribution Service.....	21
5.3.2.8	All Round Surveillance System (ARSS) Capabilities	21
5.3.2.9	Cybersecurity Requirement.....	36
5.3.2.10	Health Utilisation and Management System	37
5.3.3	Platform Camera Assembly	38
5.3.3.1	General Requirement	38
5.3.3.2	Day Camera.....	40
5.3.3.3	TI Camera	41
5.3.3.4	Operating Power	42
5.3.4	Bird Eye View Cameras (BEV).....	43
5.3.5	Intelligent Driver Display Panel (IDDP).....	43

Page 2 of 80

CO_CONFIDENTIAL

CO_CONFIDENTIAL

5.4	Mechanical Requirements.....	49
5.5	Electrical Requirements	50
5.6	Configuration Management.....	51
5.7	EMI / EMC and Operating Voltage Requirement.....	52
5.7.1	Applicable Documents	52
5.7.2	EMI / EMC Requirements	53
5.7.3	Power Requirements	57
5.8	Environment Requirements.....	59
5.8.1	Applicable Documents	59
5.8.2	Responsibilities of Contractor	60
5.8.3	Test Requirements.....	66
5.8.4	Requests for Waiver	67
5.9	Safety Requirements.....	68
5.9.1	Applicable Documents	68
5.9.2	Excessive Temperature	68
5.9.3	System Safety Requirements for Software.....	70
5.9.4	Safety Critical Item (SCI) and Reliability Critical Items (RCI).....	70
5.10	Acceptance Requirements	71
5.10.1	General.....	71
5.10.2	In-Process Inspection & Testing	72
5.10.3	Type of Acceptance Tests.....	72
5.10.4	System Verification	75
5.10.5	Acceptance Test Documentation	75
5.10.6	Acceptance Test Procedures (ATP).....	76
5.10.7	Acceptance Tests Reports (ATR) Requirements.....	76
5.10.8	General Requirements / Preparation Prior to Tests.....	77
5.10.9	Design Review.....	77
5.11	Contract Data Requirements List (CDRL)	78
5.12	Integrated Logistics Support (ILS) Requirements	80
5.13	Reliability & Maintainability Requirements.....	80

Page 3 of 80

CO_CONFIDENTIAL

CO_CONFIDENTIAL

5.14 Quality Assurance..... 80
5.15 Software Development Requirements..... 80
5.16 ARSS Requirements..... 80
5.17 Deliverables and Schedule..... 80

CO_CONFIDENTIAL

CO_CONFIDENTIAL

1 INTRODUCTION

1.1 This specification defines the requirement for Hunter Enhancement Vision System.

1.2 The key essential functions of the Vision System are as follows:

- **Close Hatch Driving (CHD)** - Provide streaming of real-time video images with augmentations such as OSD lines from cameras to the Driver 3-in-1 Display Panel (IDDP) with a backup feeds from Video network for redundancy. Video processor should cater for other types of augmentation given sufficient processing power.
- **All Round Surveillance System (ARSS) Capabilities** - Provide a selection of video images with target augmentation and stitching to achieve up to 360 degree view around the vehicle, including Bird Eye View and independently send the video images to the devices terminals with minimal video latency introduced.
- **Automatic Target Detection/ Recognition/ Tracking (ATD/ R/ T)** - Capability to automatically detect, classify and track vehicular target and human target across multiple cameras.
- **Video Recording Function** – Provide recording function for all video inputs and allow video playback.
- **Scalability** - Ability to grow and manage increased video demand and ability to cater for future insertion of at least 1x RTX 3000 GPU (with processor if required) or equivalent for anticipated future video analytics operations.

1.3 The scope of supply for the Vision System shall consist of the following sub-systems:

Page 5 of 80

CO_CONFIDENTIAL

CO_CONFIDENTIAL

- i. Video Server
- ii. Video Switch
- iii. Platform Camera Assembly with edge processing
- iv. Bird Eye View (BEV) Cameras
- v. Intelligent Driver Display Panel

2 OBJECTIVE

2.1 This Technical Specification (TSP) specifies the requirements for the design, built and qualification of the Vision System including:

- i. Technical and performance requirements
- ii. Configuration management requirements
- iii. EMI/EMC and power requirements
- iv. Environmental requirements
- v. Verification, validation and acceptance requirements
- vi. Integrated logistics support (ILS) and reliability & maintainability (R&M) requirements
- vii. Quality requirements
- viii. Delivery requirements

CO_CONFIDENTIAL

Page 6 of 80

3 REFERENCES

Reference Prefix	Reference Description
IEC 60529	Degrees Of Protection Provided By Enclosures (IP Code)
IEC-61000-4-2	International Standard Testing and Measurement Techniques
MIL-STD-1472G	Human Engineering design criteria for military systems equipment and facilities
MIL-STD-461E	Electromagnetic Interference Characteristics Requirements for Equipment
MIL-STD-1275B	Characteristics of 28 Volt DC Electrical Systems in Military Vehicles
MIL-STD-464C	Electromagnetic Environmental Effects Requirements for Systems
MIL-STD-810E	Environmental Test Methods and Engineering Guidelines
MIL-STD-882E	Standard Practice for System Safety

3.1 It is assumed that the latest revisions of the mentioned standards are referred to, unless specifically stated.

3.2 In cases where non-military standards and specifications are used in lieu of the above, details of such standards and specifications will be discussed and agreed upon between the parties.

CO_CONFIDENTIAL

4 DEFINITIONS

Abbreviation	Definition
CHD	Closed Hatch Driving
ARSS	All Round Surveillance System
ATD	Automatic Target Detection
ATR	Automatic Target Recognition
ATT	Automatic Target Tracking
AVR	Audio Video Recording
BEV	Bird Eye View
UIT	User Interface Terminal
IDDP	Intelligent Driver Display Panel
GQR	General Quality Requirement
OSD	On Screen Demand
OMG	Object Management Group
DDS	Data Distribution Service
NTP	Network Time protocol
EO	Electro-Optics
ICS	Independent Commander Sight
BMS	Battlefield Management System
ICIT	Installation, Checkout, Integration/Calibration and Testing
PDR	Preliminary Design Review
HUMS	Health Utilisation and Management System
FOV	Field of View
ESS	Environment Stress Screening

CO_CONFIDENTIAL

CO_CONFIDENTIAL

5 TECHNICAL SPECIFICATIONS

This section states in detail and define the various aspect of the technical specification of the Vision System.

5.1 Design References

N/A

5.2 Product Quality Requirement

The following requirements shall apply to the Vision System, referred to as “the system” in this section, where applicable.

5.2.1 General Quality Requirements (GQR)

5.2.1.1 The following governing document shall be provided to Contractor to meet the relevant quality standards for the fabrication, design, manufacturing and development of the Vision System.

Document Prefix	Document Description
M-SQ-002	Supplier Quality Requirements Rev.03

5.2.1.2 The Contractor shall state the commercial practices or military workmanship standards used to meet the quality requirements. These are minimum quality requirements that the Contractor shall comply:

- a) **Compatibility:** All materials used for the Article and packaging shall be compatible and suitable for long term storage and usage.

CO_CONFIDENTIAL

CO_CONFIDENTIAL

- b) **Surface Defects:** All parts shall be free from surface defects such as, folds, wrinkles, stains, discoloration, dirt, cracks, fractures and other defects. All moving parts shall function smoothly without interference, erratic movement or malfunction. Conditions of acceptance and rejection of surface defects shall be defined in inspection plans.

- c) **Welds:** Welding procedure, inspection plan and welding standards shall be defined. Welds should be examined for completeness, and conformance to welding requirements. Weld spatter and excess weld shall be removed. The welders shall be certified in accordance with established standards to perform welding.

5.2.1.3 Workmanship Standard

- 5.2.1.3.1 Military workmanship standards ANSI/ IPC Class 3, IPC-A-610 shall be complied on Safety Critical Items (SCI). For SCI that are OEM components/assemblies, the Contractor shall present the specific standards to Buyer.

5.2.1.4 Electrical/Electronic Components/Assemblies

- 5.2.1.4.1 **Jumper Wire:** No jumper wires shall be used on any printed wiring assembly without prior approval from Buyer. Components shall not be stacked up on printed wiring assembly. Written approval shall be obtained from Buyer for each modification on any printed wiring board.

- 5.2.1.4.2 **Conformal Coating:** Conformal Coating shall be required for printed wiring and multi-layer boards in accordance with best commercial practices. MIL-HDBK-454 or equivalent shall be used as a reference for conformal coating. Acrylic conformal coating is preferred by Buyer. Connectors and fastening devices shall be of high corrosion resistance grade to resist the environment that the Article may encounter as specified in the environmental requirements section.

CO_CONFIDENTIAL

CO_CONFIDENTIAL

- 5.2.1.4.3 **Cable/ Wire:** Cable/ Wire shall be of adequate design to prevent damage due to normal military operation. In particular, the joints between connectors and the cable shall be of a design that is strong enough to take the regular flexing and tension as well as keep out any moisture that may be expected during its use. Cable / Wire should be routed away from temperature or moving parts. Cable / Wire shall not pass under / over sharp edges or points without suitable protection.
- 5.2.1.4.4 **Supports:** All parts weighing more than 7.1 grams per lead shall be supported by Clamps Panels or other mechanical means which defines mounting techniques for electronic components. Cables, harnesses or individual wires shall be supported by clamps located at sufficient spacing to eliminate sag or allow proper routing. For abrasion protection at points of contact, synthetic rubber stripping shall be used between wires and clamp panel.
- 5.2.1.4.5 **Mounting of Axial and Non-axial Leaded components:** Axial and non-axial leaded components shall only be mounted on one side of PCB. Surface mount devices may be mounted on both sides of PCB. On mixed technology boards, through-hole components are preferred to be mounted only on one side devices.
- 5.2.1.4.6 **Strain relief:** Wires exiting from connectors shall be strain-relieved.
- 5.2.1.4.7 **Electrical/ Electronic Components:** Electrical/ Electronic components selection priority shall be followed according to Mil-Spec components and AEC components certified. In the event of non-availability of the certified components requested, an industrial grade component shall be used with written approval shall be obtained from Buyer.
- 5.2.1.4.8 **Electronic assemblies:** Electronic assemblies shall comply with the latest version of IPC-A-610.

CO_CONFIDENTIAL

CO_CONFIDENTIAL

5.2.1.4.9 **Cable/ Wire assemblies:** Cable and wire harness assemblies shall comply with the latest version of IPC-A-620.

5.2.1.4.10 **Cable/Wire routing:** Power lines shall route separately with signal lines. In the event of non-adherence, shielded method shall be implemented.

5.3 **Design Quality Requirement**

The Contractor shall be responsible for the selection and design of the components to meet the requirements as stipulated in this document. The following sections specify the detail design requirements for the Vision System.

5.3.1 **System Architecture**

5.3.1.1 Figure 1 shows the proposed Vision System Architecture Block Diagram.

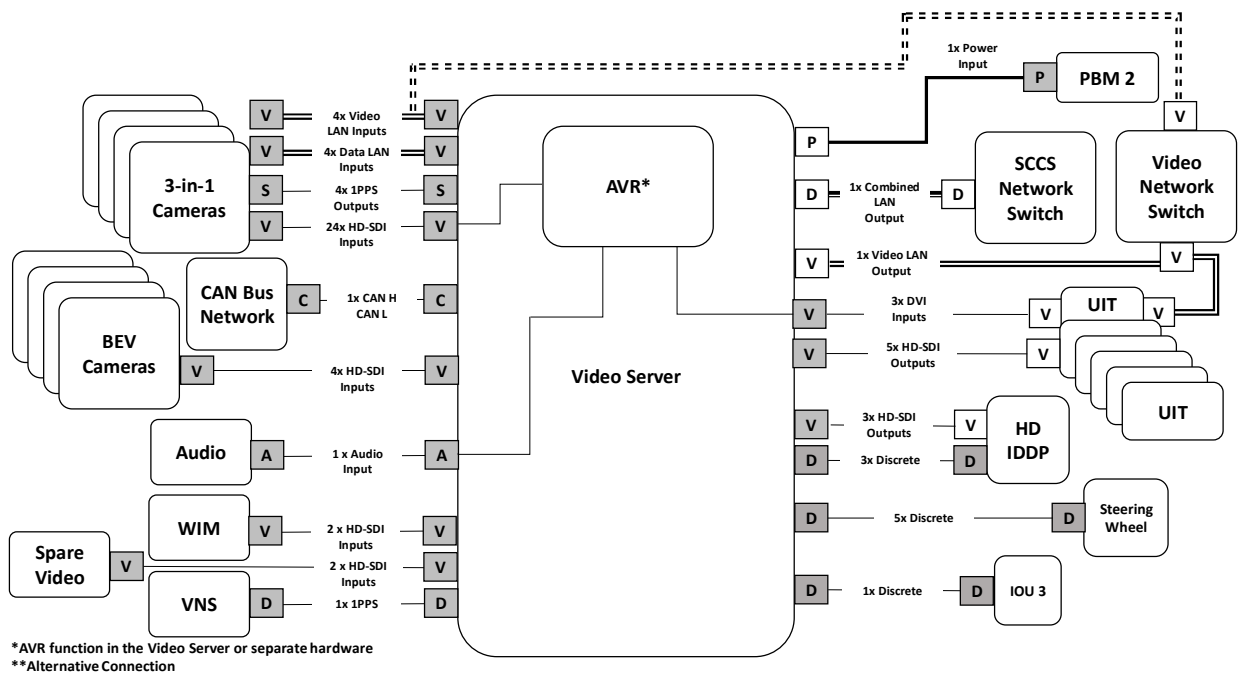

Figure 1: Proposed Vision System Architecture Block Diagram (To be finalise prior to contract signature)

CO_CONFIDENTIAL

CO_CONFIDENTIAL

5.3.1.2 The Vision System comprises of:

- Video Server for high quality video processing such as video stitching, target recognition & tracking (as a system), recording etc.;
- Platform Cameras placed strategically around the platform to give the crew comprehensive situational awareness on the battlefield;
- Bird Eye View Cameras provides an undistorted view of the vehicle immediate surroundings (from 0m up to 3.5m) reducing blind spots significantly. It shall also be able to provide coverage (preferably undistorted) from 3.5m to 5m as an option;
- Intelligent Driver Display Panel for closed-hatch driving operation.

5.3.2 Video Server

5.3.2.1 General Requirements

5.3.2.1.1 The Video Server shall be a ruggedized enclosure unit with multi-channel video (SDI/H.264) receiver and multiple video outputs for CHD and displays.

5.3.2.1.2 The baseline configuration of the Video Server shall support video distribution, ATD/R/T (as a system), video stitching, video augmentation and video enhancement tasks

5.3.2.1.3 Additional slots shall be provision for to support at least one additional Graphics Processing Unit (GPU) RTX3000 (with processor if required) or equivalent and its dedicated processor module as an option. The cooling solution shall cater for the additional GPU heat load and shall be within the maximum hardware envelope dimension in define in Section 5.4.

5.3.2.1.4 The Video Server shall allow the changing of the video source on any User Interface Terminal (UIT) without affecting the video on other UITs and IDDP.

Page 13 of 80

CO_CONFIDENTIAL

CO_CONFIDENTIAL

- 5.3.2.1.5 The Video Server shall be able to respond to requests from the IDDP and UITs for control and management of its video processing tasks:
- i. Selection of different stitched views configurations
 - ii. Selection of Picture in Picture displays from other apps (weapon, sight app, etc)
 - iii. Selection of day or night views
 - iv. Selection of display of video augmentation / ATR
 - v. Receive inputs to perform weapon/sight slewing.
- 5.3.2.1.6 The video server shall also be responsible for video de-interlacing and scaling function.
- 5.3.2.1.7 The video server shall provide redundant video feeds for the crew.
- 5.3.2.1.8 In the event that there is no video input to the Video Server for a particular channel, the affected video channel output shall display a blue raster image.
- 5.3.2.1.9 In the event that there is no video input to the Video Server for a particular channel, the affected video channel output shall display a blue raster image.
- 5.3.2.1.10 The Video Server shall have the necessary Built-In-Tests (BIT) incorporated to test hardware and its connection to the subsystem as detailed in Appendix D: Reliability and Maintainability Requirements.
- 5.3.2.1.11 The Video Server's GPU max computational loading shall not be more than 70%.

CO_CONFIDENTIAL

Page 14 of 80

CO_CONFIDENTIAL

5.3.2.1.12 Each processor shall have a CPU throughout reserve capacity at least 50% when operating at the full load. The CPU throughout reserve capacity requirement shall be defined as follows:

- System must be able to process twice the amount of load within the same duration of time, or
- CPU is idle 50% of the time, yet meeting the performance requirement when the system is operating at full load scenario. The idle time should be absolutely free from any form of processing activities, including Built-in-Tests.

5.3.2.1.13 Contractor shall provide the details function and specification of the Video Server hardware/ software to meet the requirements (e.g Interface PCB, Main Controller, GPU, Ethernet switch, FPGA, Power supplies and EMI filter etc).

5.3.2.2 Video Interface

5.3.2.2.1 The Video Server input shall be able to support the interfaces for necessary platform cameras for driving, ARSS and BEV operation.

5.3.2.2.2 Video Server input shall also support the following platform interfaces:

- i. 32 channels of HD-SDI video
- ii. 3 channels of DVI video;
- iii. 1 channel of Audio;

5.3.2.2.3 Video Server output shall support the interfaces to IDDP with redundancy when main video output is not available and 8 channels of HD-SDI video interfaces with a single GPU with the potential to increase with the addition of a second GPU.

CO_CONFIDENTIAL

CO_CONFIDENTIAL

5.3.2.2.4 The Video Server shall support direct HD-SDI feeds to the IDDP and five crew UITs. The sixth crew UIT shall be provided direct HD-SDI feeds when the second GPU is added.

5.3.2.2.5 Table 1 shows the required glass-to-glass latency for the video output.

Table 1 : Required glass-to-glass latency for the video output

View Glass to Glass	Single Camera View (Day, TI and Fusion) (HD-SDI)	Stitched Camera View (Day and TI) (HD-SDI)	Single HD Video Stream for one UIT (Stitched or non-stitched) (Video LAN)
Camera to IDDP	< 140ms	NA	<300ms
Camera to UIT	< 140ms	< 200ms	<300ms

5.3.2.2.6 All feeds should be independent of each other, i.e. changing of the video source on any UIT and IDDP will not affect the video on other UITs and IDDP.

5.3.2.2.7 The Video Server shall provide at least 7 auxiliary feed simultaneously via the shared video LAN to the IDDP and 6 crew UITs without performance degradation.

5.3.2.2.8 For ARSS Layout View with ATD /R/ T, the video latency shall be less than 300ms for all UITs.

5.3.2.2.9 The Contractor shall propose the video format to output to the IDDP and UITs in order to meet the latency requirement as stated in Table 1.

5.3.2.2.10 Contractor shall provide the estimated system latency as mentioned above in the proposal submission.

CO_CONFIDENTIAL

CO_CONFIDENTIAL

- 5.3.2.2.11 Actual measurement shall be carried out upon availability of hardware or after PDR.
- 5.3.2.2.12 The Video Server shall built-in of Gigabit Ethernet switch with at least 12 ports for communication between the cameras and the video server.
- 5.3.2.2.13 The Vision System shall include an external switch with at least 12 ports to support H.265/264 streaming video format to the 6 UITs.
- 5.3.2.2.14 The Video Server shall communicate with the platform via Ethernet and CAN bus (MIL-CAN).
- 5.3.2.2.15 The Video Server shall not have terminating resistor (120 Ohm) between CAN H and CAN L.
- 5.3.2.2.16 The Video Server shall support video input formats for HD-SDI (SMPTE 292 protocol), DVI and Auxiliary Compressed Video Over IP (H.265/264) – based on routing inputs.
- 5.3.2.2.17 The Video Server shall also support video output formats for HD-SDI (SMPTE 292 protocol), and Auxiliary Compressed Video Over IP (H.265/264) – based on routing inputs.

5.3.2.3 Control Interfaces for Automatic View Change

- 5.3.2.3.1 The Video Server shall be able to accept 24Vdc discrete inputs to allow toggling/ changing of different views from external source.
- 5.3.2.3.2 All discrete inputs shall reference to the Video Server.
- 5.3.2.3.3 Table 2 shows the discrete inputs and functions reference to the vehicle gear selection.

CO_CONFIDENTIAL

Page 17 of 80

CO_CONFIDENTIAL

Table 2: Discrete input and functions reference to the vehicle gear selection

Inputs	Functions	
	Forward/ Neutral Gear	Reverse Gear
Gear Signal	Gear Forward Signal = 0 Toggle BEV to overlay center IDDP or UIT display for a duration of X sec (to be determined) before toggling the overlay view off	Gear Reverse Signal = 1 Toggle BEV to overlay center IDDP or UIT display for a duration of X sec (to be determined) before toggling the overlay view off
Toggle Up	Toggle between Front & Side Views	Toggle to Front View
Toggle Down	Toggle to Rear View	Toggle between rear and side view
TI Button	Change to TI View	Change to TI View
Ramp Button	Change to Ramp View (using 1 of the BEV camera feed)	Change to Ramp View (using 1 of the BEV camera feed)
Normal Button	Change to Front View	Change to Rear View

CO_CONFIDENTIAL

CO_CONFIDENTIAL

5.3.2.4 Operating Power

5.3.2.4.1 Video Server shall operate at nominal voltage 28Vdc and input range from 18Vdc to 32Vdc in compliance to MIL-STD-1275B.

5.3.2.4.2 Contractor shall specify the nominal, peak and maximum power consumption of the Video Server in the proposal.

5.3.2.5 Synchronization Feature

5.3.2.5.1 The Video Server shall receive the 1PPS signal from the platform navigation system to synchronize the video frames for video stitching algorithms and other high accuracy time synchronization application.

5.3.2.5.2 The Video Server shall further redistribute the 1PPS signals to Platform Cameras.

5.3.2.5.3 RFC 5905 Network Time protocol (NTP) shall be implemented to synchronize the Data Time via platform navigation system.

5.3.2.5.4 Timestamp and/or relevant video telemetries (frame's area of interest, FOV, position, etc) shall be embedded into the digital video in accordance to Motion Imagery Standards Board (MISB) 0605.6 standard for uncompressed video (MISB standard 0604.3 for compressed video) to enable subsequent processing and/or exploitation of the video frames.

5.3.2.6 Video and Audio Recorder

5.3.2.6.1 The Video and Audio Recorder shall provide the following recording functions:

- a) UITs' screen Recording
- b) Platform Cameras' Recording

CO_CONFIDENTIAL

CO_CONFIDENTIAL

5.3.2.6.2 When the media storage is full, the Video Server shall replace the oldest recorded video with the latest recording with time stamp for both recording functions stated in Section 5.3.2.6.4 and 5.3.2.6.5

5.3.2.6.3 The audio inputs shall be synchronized to the recorded images and is applicable to both recording functions stated in Section 5.3.2.6.4 and 5.3.2.6.5

5.3.2.6.4 UITs' screen Recording

5.3.2.6.4.1 The Video Server shall be able to support real time video and audio recording of the UITs' comprising of the VC, Gunner and Center UITs via DVI (TBD) during RCWS firing.

5.3.2.6.4.2 The video server shall have the capability to allow extraction of data in a secure way. Contractor shall propose the solution of how to perform this action in the proposal submission.

5.3.2.6.4.3 The Video Server shall allow control function of the recorded video feed e.g playback, fast forward, pause of the recording via inputs from the UIT. Deletion of videos shall be password controlled.

5.3.2.6.4.4 The platform shall control the Video Server to start/stop recording via 2 signals (ARM and Trigger) relayed via DDS. The Video Server shall overlay a Trigger icon and/ or an ARM icon over the live video stream and record as a single video with timestamp based on the received signal.

5.3.2.6.4.5 The Video Server shall start recording upon receiving the ARM via DDS topic and stop recording via DDS topic upon removal of the ARM signal.

5.3.2.6.4.6 The Video Server shall start the recording of another video stream 15 sec prior upon receiving the Trigger signal and stop 30 sec after the Trigger signal is deactivated

Page 20 of 80

CO_CONFIDENTIAL

CO_CONFIDENTIAL

5.3.2.6.5 Platform Cameras' Recording

- 5.3.2.6.5.1 The Video Server shall also be able to record only all the Platform Camera Assembly feeds (Day and TI) upon vehicle power on. Each camera output shall be recorded to one media file.
- 5.3.2.6.5.2 One storage media (cannot be removed) to support at least 24hrs of recording or storage media space of 1TB whichever is more.
- 5.3.2.6.5.3 The operator is not able to playback the video. However, they are able to view the video for functional check prior to operation.

5.3.2.7 Data Distribution Service

- 5.3.2.7.1 The data distribution (command and control) within the platform shall use the Object Management Group (OMG) Data Distribution Service (DDS) with security plugins that are aligned with OMG DDS-Security Specification. The interface shall comply with Real-Time Publish-Subscribe DDSI Wire Protocol (RTI Connex DDS Secure 5.3.1 and RTI Connex DDS Secure plugins). Topics definition and message interface specification shall be finalised during Integration Review.
- 5.3.2.7.2 The Video Server shall process and format the video feeds to an open digital video format (e.g H.264) for video distribution over the Video LAN. The Contractor shall recommend the most suitable format for Buyer approval during design review.

5.3.2.8 All Round Surveillance System (ARSS) Capabilities

The Contractor shall provide the following All Round Surveillance System (ARSS) capabilities for the Vision System.

CO_CONFIDENTIAL

CO_CONFIDENTIAL

5.3.2.8.1 Video Stitching Capabilities

- 5.3.2.8.1.1 Video Stitching shall employ video feeds from necessary cameras (Electro-Optics (EO): day or TI: night) mounted around the vehicle platform chassis to present a real-time stitched view in both day and TI mode.
- 5.3.2.8.1.2 The Vision System shall provide the stitched video streams to be displayed on the UITs and optionally for IDDP upon request by the various display. The stitched view shall be able to support up to 180° over any sector around the vehicle using any combination of cameras as required. A reverse view of up to 180° shall simultaneously be made available for display.
- 5.3.2.8.1.3 The Video Server shall continuously truncate the stitched image into 3 equal sections of 1920 x 1080 pixels images for presentation to 3x UIT for presentation of a seamless video image across 3 UIT and optionally for IDDP.
- 5.3.2.8.1.4 The Video Server shall maintain the bearing information of each view with respect to the vehicle platform's orientation and overlay the information on the video feed.
- 5.3.2.8.1.5 This bearing information of each view will also be required for provision to the UITs for the Battlefield Management System (BMS) to perform touch to slew functions.
- 5.3.2.8.1.6 The Video Server shall allow UIT to control rotation of FOV across any sector based on input from the UIT. The control scheme shall be presented and agreed in the design review.
- 5.3.2.8.1.7 The Video Server shall provide Area of Interest views which display any selected part of the stitch view.
- 5.3.2.8.1.8 The Video Server shall support the UITs in the manipulation of the Area of Interest views and stitched view such as zoom or slew.

Page 22 of 80

CO_CONFIDENTIAL

CO_CONFIDENTIAL

5.3.2.8.2 Video Augmentation Capabilities

5.3.2.8.2.1 The Video Server shall be able to allow real-time ATD/ R/ T augmentations onto the stitched video streams and individual video streams.

5.3.2.8.2.2 The Video Server shall add real-time augmentation from operator selection or other systems onto the video streams and to be made available to each user.

5.3.2.8.2.3 The augmentation types (published on Data LAN (DDS)) shall include but not limited to:

- i. Lines
- ii. Bounding boxes
- iii. Text and ascii symbols
- iv. Augmentations from other systems (in the form of metadata)
- v. All the above in different colors

5.3.2.8.2.4 The Video Server shall include calibration tools/features for Operator to calibrate static augmentation/overlays such as lane markers, distance markers based on vehicle configuration.

5.3.2.8.2.5 The Contractor shall provide necessary tools and procedures to allow Buyer to perform customization and updates of the simple non-intelligent augmentation.

5.3.2.8.3 Video Enhancement Capabilities

5.3.2.8.3.1 The Video Server shall provide video enhancement features such as Sensor fusion; Image contrast; Brightness; Warp correction; etc.

CO_CONFIDENTIAL

Page 23 of 80

CO_CONFIDENTIAL

5.3.2.8.3.2 The Video Server shall perform the blending of views to improve the video matching of the stitched images for better visualisation for the operator.

5.3.2.8.4 Automatic Target Detection/ Recognition (ATD/ R)/ Automatic Target Tracking (ATT) Capabilities

5.3.2.8.4.1 The Automatic Target Detection/ Recognition (ATD/ R) function shall covers full 360° around the vehicle and works with EO cameras and IR sensors on the vehicle.

5.3.2.8.4.2 The ATD/ATR function shall identify potential target/ object appearing around the vehicle platform when the vehicle is static or moving at speeds up to 32kph in on road and off road scenarios.

5.3.2.8.4.3 Target classification shall follow the hierarchy specified in Figure 2 depending on the confidence level the classifier is trained to at any point in time using Day and TI Sensor.

5.3.2.8.4.4 The Machine learning software shall be able to detect to level 3 for “Humans” and Level 2 for “Vehicles”.

5.3.2.8.4.5 Level 3 and Level 4 classification for “Vehicle” will be best efforts by Contractor according to data provided by end-customer.

5.3.2.8.4.6 The ATD/ATR function shall minimally be able to detect and differentiate Humans and Vehicles (level 2). It shall revert to non-specific classifications (Humans and Vehicles) when the confidence level of the detector is low (threshold to be advised by the Contractor).

CO_CONFIDENTIAL

CO_CONFIDENTIAL

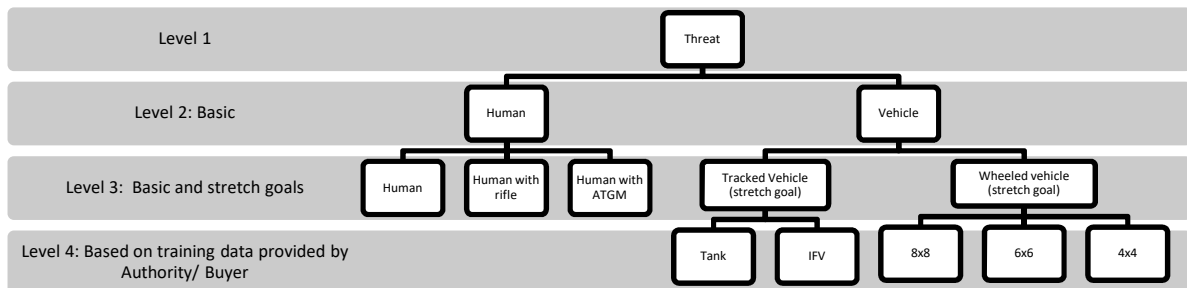

Figure 2: Target/ Object Classes Tree

- 5.3.2.8.4.7 The ATD/ATR function shall progressively be improved throughout its development cycle based on the classification table in Figure 2.
- 5.3.2.8.4.8 The ATD/ATR function shall make use of deep learning algorithms and computer vision techniques to allow for future growth for further sub-classes or target/ object attributes as highlighted in Figure 2.
- 5.3.2.8.4.9 The ATD/ATR function shall meet the following performance requirements:
- i. Perform detection/ recognition in harsh environment (e.g. Movement through undulating cross country or urban terrains, dusty or rainy conditions, smoke obscurant, etc.)
 - ii. Provides 360° continuous background monitoring of both the Day and TI video stream in the background, while the operator performs other mission tasking.
 - iii. The ATD/ R/ T algorithm shall be able to detect and recognise at least 5 targets on each video feed in day and night scenarios or 40 targets across all the video feeds of the cameras around the vehicle platform.

CO_CONFIDENTIAL

CO_CONFIDENTIAL

- iv. Performs small target detection/ recognition. The detectable/ recognisable target size on the video feed by the system shall be minimally 16 x 16 pixels in appearance.
- v. The required performance ranges for ATD/ R at 90% Probability of Detection (PD) are as shown in Table 3.

Table 3: ATD/ R at 90% Probability of Detection (PD)

Sensor Type	Camera Resolution	Camera Setting	ATR Range (m) Human (Frontal) = 0.5 m x 1.8 m	ATR Range (m) Vehicle = 2.3 m x 2.3 m
			P = 90%	P = 90%
EO camera (day)	1920 x 1080 (FHD)	HFOV (64°)	At least 80 m	At least 200 m
		HFOV (90°)	At least 60 m	At least 150 m
TI sensor (night)	640 x 480 (VGA)	HFOV (64°)	At least 30 m	At least 70 m
		HFOV (90°)	At least 20 m	At least 50 m

- vi. Average False Alarm Rate (FAR) in an hour shall not be more than 20%.
- vii. Missed detection (False Negative, FN) shall not be more than 10%.

5.3.2.8.4.10 The Contractor shall provide Automatic Target Tracking (ATT) with the following features:

- i. Upon positive detection, the video server shall provide the necessary information such as camera coordinate frame (fixed reference frame), IMU values from detected cameras (dynamic values), raw detection bounding box position, estimated class of targets, range estimate, track IDs and associated error/covariance matrix for the BMS to calculate the LAT/LONG position of the detected target.

CO_CONFIDENTIAL

CO_CONFIDENTIAL

- ii. ATT shall be capable of automatically tracking multiple detected targets across different cameras around the vehicle platform
- iii. ATT shall aid in improving the Probability of Detection (PD) of the targets.

5.3.2.8.4.11 ATD/ R and ATT software shall output the object classification type and include, but not limited to, the following object track information in a metadata format (to be used by other sub- systems in the vehicle.

- i. Object tracked ID
- ii. Object bound box information (X, Y, W, H, label & detection score) where;
 - Image coordinates (X,Y) : left top corner of bounding box
 - W : width of bounding box in pixel
 - H : height of bounding box in pixel
 - Label : object class
 - X, Y, W, H should be normalized values with respect to the image resolution
- iii. Estimated range of detected target/ object
- iv. Bearing and location with respect to vehicle
- v. Estimated target/ object trajectory (i e. movement of target/ object direction)

5.3.2.8.4.12 The end-to-end target acquisition processing shall be limited to within 50ms, including tracking, recognition and overlaying on the videos.

CO_CONFIDENTIAL

Page 27 of 80

CO_CONFIDENTIAL

5.3.2.8.5 All Round Surveillance System (ARSS) Layout View

- 5.3.2.8.5.1 The ARSS layout view allow the crews to conduct surveillance of the vehicle's external surroundings from within the vehicle securely without exposure to impending targets.
- 5.3.2.8.5.2 The request command for the ARSS layout view shall be done via DDS.
- 5.3.2.8.5.3 For video distribution over the Video LAN, refer to Section 5.3.2.7.2.
- 5.3.2.8.5.4 Each layout shall be of full screen (1920 x 1080 pixels) and comprise of multiple video windows with their respective video attributes.
- 5.3.2.8.5.5 The creation of each layout shall be based on the following video attributes:
- i. Identifier for video source (inclusive of videos with custom On Screen Demand preconfigured by Contractor application);
 - ii. Offset (padding) from the top left and bottom right of the video source;
 - iii. Corresponding pixel position for every video window referencing to screen display top left as (0, 0) and
 - iv. Corresponding width and height in number of pixels for every video window.
Note: Only the width have to be of even number due to the YUV422 format.
- 5.3.2.8.5.6 The Video Server shall transmit the health and BIT statuses via DDS.
- 5.3.2.8.5.7 The Video Server shall transmit the layout on response to command at no longer than 50millisecond.
- 5.3.2.8.5.8 The Video Server shall transmit the current layout enumeration via DDS.

CO_CONFIDENTIAL

CO_CONFIDENTIAL

- 5.3.2.8.5.9 The layout shall allow up to a maximum of 16 video windows to form 1 layout regardless of the video source (i.e. 16 video windows of 1 video source is allowed).
- 5.3.2.8.5.10 Video latency shall not be more than one or two frames or noticeable laggy of image between videos from different camera of same scene.
- 5.3.2.8.5.11 The Video Server shall fill the colour black for areas that are not occupied by any video window.
- 5.3.2.8.5.12 The Video Server shall fill the video window with black colour in the event of any errors specific to its layout creation. E.g. when padding pixel value is out of video source range, the video output should be black.
- 5.3.2.8.6 Custom On Screen Demand (OSD)**
- 5.3.2.8.6.1 The Video Server shall allow uploading and adjustments/ calibration of custom OSDs via UITs.
- 5.3.2.8.6.2 Contractor shall provide the required tool and procedures for Buyer to carry out OSD adjustment or programming including live calibration and adjustment of the OSD on the video server if applicable.
- 5.3.2.8.6.3 The Video Server shall allow a minimum of 256 custom OSDs.
- 5.3.2.8.6.4 The Video Server shall allow uploading of custom OSDs in various resolution including 1920 x 1080 pixels, 1024 x 768 pixels, 1280 x 720 pixels and 640 x 480 pixels.
- 5.3.2.8.6.5 The custom OSDs to be uploaded shall have a transparency (alpha) channel that Video Server should use to determine transparent pixels.
- 5.3.2.8.6.6 The Video Server shall allow retrieval of uploaded OSDs for verification purposes after uploading, adjustments or calibration.

Page 29 of 80

CO_CONFIDENTIAL

CO_CONFIDENTIAL

- 5.3.2.8.6.7 The uploading, adjustment or calibration process shall not interfere with the internal software design of the Video Server causing and resulting in any faults or corruption to the firmware.
- 5.3.2.8.6.8 The custom OSDs shall be resized by the Video Server accordingly based on the video window width and height.
- 5.3.2.8.6.9 The API and protocol for uploading of custom OSDs shall be provided.
- 5.3.2.8.6.10 A functional unit/emulator shall be provided by the Contractor to allow STELS to perform software development as indicated in Appendix I.
- 5.3.2.8.6.11 The ARSS layout views shall consist of at least, but not limited to configuration as shown in Appendix G: ARSS requirements of this specification document for the layout views configuration on single UIT display and ARSS stitched panoramic view layouts on 3x UITs video wall.
- 5.3.2.8.6.12 Contractor shall propose the presentation of the ARSS Layout and video permutation with option to meet the requirements indicated in Appendix G: ARSS Layout and Stitched View
- 5.3.2.8.7 Installation, Checkout, Integration/Calibration and Testing (ICIT) Support for ARSS Capabilities (Inclusive of ATD/ T/ R Capabilities)**
- 5.3.2.8.7.1 The Buyer shall be informed of the acceptance tests in Contractor Premises and shall give Contractor at least one month's notice to attend the acceptance tests.
- 5.3.2.8.7.2 The Contractor shall perform the integration, commissioning and testing of the Vision System for the local prototype and the first two Articles of the production vehicles in Singapore. The Contractor shall continue to provide technical support during production for the subsequent units.

CO_CONFIDENTIAL

CO_CONFIDENTIAL

5.3.2.8.7.3 The Contractor shall certify, provide training and all necessary installation, integration/ calibration tools and integration/testing procedures to Buyer for the integration of the Vision Systems on the platforms during series production.

5.3.2.8.7.4 All ICIT plan pertaining to the supplied system and software shall be provided 1 month prior to PDR.

5.3.2.8.7.5 ICIT results shall be provided no longer than 1 month after completion of ICIT.

5.3.2.8.8 Systems Engineering Training

5.3.2.8.8.1 Contractor shall provide software development kit, all necessary support, provisions, training, knowledge transfer and tools for STELS to perform independent software upgrades and new software development for the Vision System (including DMS, IDDP and the cameras).

5.3.2.8.8.2 The Contractor shall conduct Systems Engineering training sessions for the usage and workflow of the system to Buyer in addition to the ILS training requirements detailed in Appendix C: ILS requirements of this specification document.

5.3.2.8.8.3 The Training shall allow and certify Buyer to perform the following:

- i. Perform ICIT and calibration for the ARSS capabilities (including stitching view calibration, etc).
- ii. Perform software update and installation for the Video Server.
- iii. Perform troubleshooting to LRU level.

5.3.2.8.8.4 The Contractor shall provision the necessary interfaces for an ATD/R, ATT training kit (hardware and software) so that the training of updated models can be done in-house by Buyer in the future. It should be agnostic to the change of GPU/NN models.

Page 31 of 80

CO_CONFIDENTIAL

CO_CONFIDENTIAL

5.3.2.8.8.5 The hardware package for training from Contractor to fulfil Section 5.3.2.8.8.4 shall include, but not limited to, computer terminals and AI recording box for training.

5.3.2.8.8.6 The software package for training from Contractor to fulfil Section 5.3.2.8.8.4 shall include, but not limited to, data collection, annotation and model training tool kits.

5.3.2.8.9 ARSS Scenario Generation and Performance Validation

5.3.2.8.9.1 The Contractor shall perform a series of verification tests to verify the performance of the ATD/ATR/ ATT functions

5.3.2.8.9.2 The Contractor shall work together with Buyer and the Authority for the verification and validation of the system performance.

5.3.2.8.9.3 The Contractor shall provide the test plan for Buyer's approval 1 month before test conduct and submit the test results 1 month after test conduction.

5.3.2.8.9.4 The Contractor shall propose the necessary verification tests to verify the ATD/ATR/ ATT performance for Buyer's approval. The tests shall cover, but not limited to:

- i. Measurements of detection probability (50% & 90%) versus detection ranges;
- ii. Measurements of performance parameters using with Golden Data Set and without Golden Data Set (Live tests);
- iii. Probability of Detection, PD;
- iv. Average False Alarm Rate (FAR);
- v. Missed Detection (False negative, FN);

CO_CONFIDENTIAL

CO_CONFIDENTIAL

- vi. Recall per class;
- vii. Inference time (i.e. process time of using a trained Deep Learning model to make predictions against previously unseen data); and
- viii. How small a target (i.e. pixel & actual target size) the ATD/R/T can pick up at the furthest detection distances.

5.3.2.8.9.5 The Contractor shall propose, design, plan and execute the basic verification scenarios. Any proposed scenarios shall be subjected to review and approval of Buyer.

5.3.2.8.9.6 For the performance verification of test scenarios, Vehicle shall be in static position and target shall be in static and moving (up to 32kph) condition for the test scenarios.

5.3.2.8.9.7 For moving vehicle (up to 32kph) test scenarios, the Contractor shall carried out the test for data collection and present to the Buyer during design review.

5.3.2.8.9.8 The proposed verification scenarios shall encompass or exceed the basic scenarios shown in Figure 3 and Figure 4.

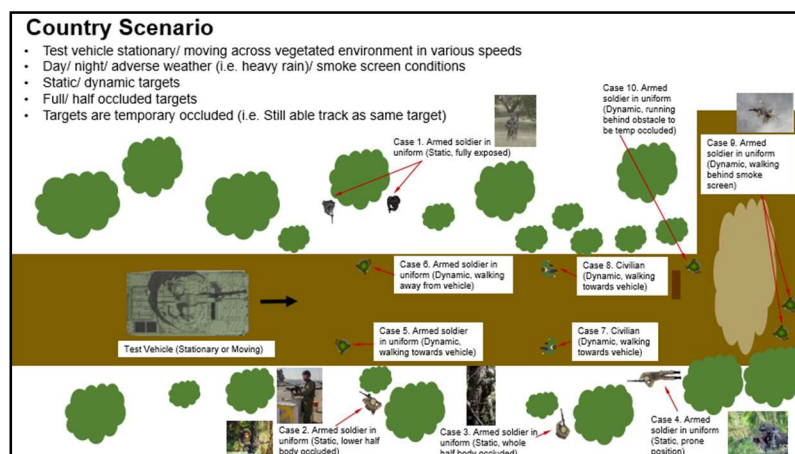

Figure 3: Basic Country Scenario for ATD/ATR/ATT validation

CO_CONFIDENTIAL

CO_CONFIDENTIAL

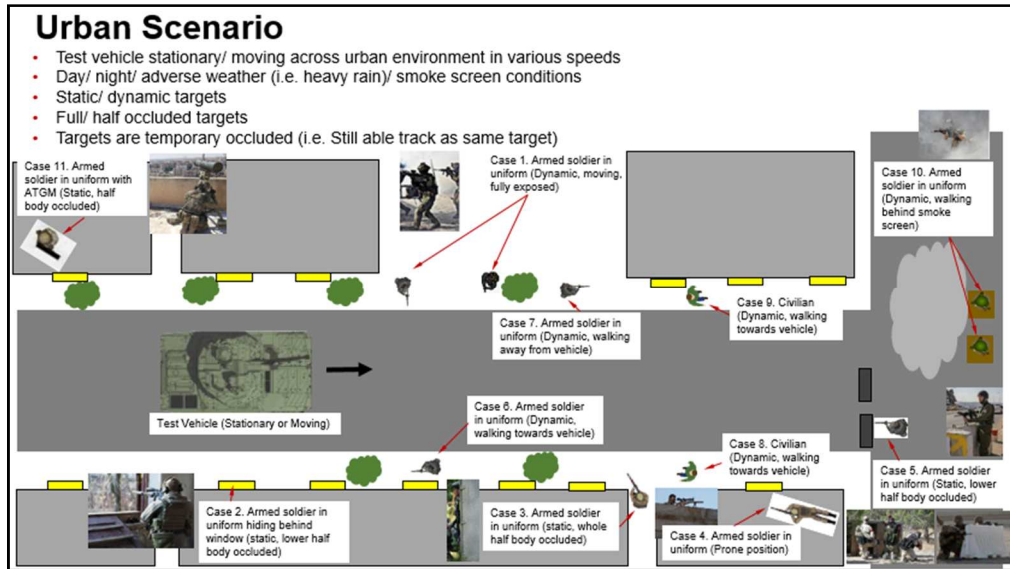

Figure 4: Basic Urban Scenario for ATD/ATR/ATT validation

5.3.2.8.10 Establishment of Golden Test Set with Authority

- 5.3.2.8.10.1 A Golden Test Set shall be formulated from the scenario generation for Human and Vehicle detections in local environment.
- 5.3.2.8.10.2 The Golden Test Set shall be jointly developed with Authority, the User and Buyer and Contractor shall concur the use of this Golden Test Set as test metrics for final performance verification.
- 5.3.2.8.10.3 The Golden Test Set shall be a one-time effort and shall be recorded for future ATD/R, ATT algorithm verifications.
- 5.3.2.8.10.4 The Contractor shall also carry out performance verification and validation on the Golden Test Set. If the performance is below par, the Contractor shall repeat the verification and validation procedure again after an iteration of retraining to refine the existing model supplied by the Contractor.

CO_CONFIDENTIAL

CO_CONFIDENTIAL

5.3.2.8.10.5 The Authority shall facilitate and provide test platform, test ground and test subjects (including personnel and vehicles) for generation of the Golden Test Set.

5.3.2.8.10.6 The Contractor shall provide the recording functions for the Vision System to be able to extract data sufficient to perform and train data as part of the Golden Test Set. Buyer shall support video recording crew and administrative vehicle for a duration of not exceeding 1 month to support the Authority in the generation of the Golden Test Set.

5.3.2.8.11 Test Documentation

5.3.2.8.11.1 The Contractor shall submit a test plan detailing the tests for approval 1 month prior to the System performance validation tests.

5.3.2.8.11.2 Test results and video footages of the validation tests conducted shall be submitted to Buyer no longer than 1 month after the completion of the System performance validation tests.

5.3.2.8.12 Model Training and Support

5.3.2.8.12.1 The Contractor shall provision for at least two (2) ATD/ R target model retraining sessions after acceptance of the production version by Authority with the following efforts:

- i. Data collection
- ii. Annotation
- iii. Model training
- iv. ATD/ R performance validation based on Golden Test Set
- v. Re-deployment of updated model

CO_CONFIDENTIAL

CO_CONFIDENTIAL

5.3.2.9 Cybersecurity Requirement

5.3.2.9.1 Security Management and Governance framework

5.3.2.9.1.1 Security Management

- Incorporate the security activities from the security by design framework in the system development lifecycle process

5.3.2.9.1.2 Security Risk Management

- Implement risk management process to assess security risks and implement control measures for mitigating the risks.
- Description of the proposed security risk management process and how it shall be implemented.

5.3.2.9.2 Hosting

5.3.2.9.2.1 Vulnerability Scanning

- The following services shall be disabled: FTP, Telnet, SMBv1.0, SMBv2.0, SNMPv1, SNMPv2

5.3.2.9.3 Application Security

5.3.2.9.3.1 Application Development

- Static Code Analysis
- Scan for OWASP Top 10 vulnerability
- Logging of input validation failure. (example unauthorised access)

CO_CONFIDENTIAL

CO_CONFIDENTIAL

5.3.2.10 Health Utilisation and Management System

- 5.3.2.10.1 The video server shall provide the health and utilisation status of the platform's all round surveillance system to platforms HUMS for logging and monitoring.
- 5.3.2.10.2 The health and utilisation status shall include, but not limited to, the following;
- Video Server's on time, On duration and Off Time
 - Average Video Server's CPU Load over five(5) minutes
 - Average Video Server's Memory Utilisation over five (5) minutes
 - Video Server's CPU temperature
 - Driving and surveillance camera utilisation hours
 - Health status data for driving and surveillance cameras as well as their associated Line-Replacement Unit (LRUs)
 - Power-On BIT status of Video Server, driving and surveillance cameras
 - User Initiated BIT status of Video Server, driving and surveillance cameras
 - Fault codes of Video Server's, driving and surveillance cameras
- 5.3.2.10.3 The purpose of the HUMS is to monitor the usage of the Vision System, real time fault reporting and make recommendation to the Operator for Condition Based Maintenance.
- 5.3.2.10.4 The Contractor shall propose and provide additional health and utilisation status information necessary to give a health status of the Vision System.
- 5.3.2.10.5 The Contractor shall provide step-by-step troubleshooting procedures for all failures which includes both symptomatic faults and Built in Test (BIT) faults.

Page 37 of 80

CO_CONFIDENTIAL

CO_CONFIDENTIAL

- 5.3.2.10.6 The Contractor shall also provide the following supporting information:
- Overall system schematics (electrical/hydraulic/pneumatic & etc).
 - BIT documentation which shall include the software logic and the permutation of possibilities that triggers the fault for all the faults in the list. It shall also include all the parameters and thresholds that triggers the fault for all the faults in the list.
 - Models or some reasonable way to illustrate any concealed parts or subsystems which will aid the operator in locating the component of interest and perform space accessibility analysis as part of the troubleshooting procedures.
 - List of Line Replacement Unit(s) (LRUs) that correspond to each and every fault in the fault list if applicable.
- 5.3.2.10.7 The information status and notification data shall only be published and subscribed using OMG Data Distribution Service for Real time system (DDS).
- 5.3.3 Platform Camera Assembly**
- 5.3.3.1 General Requirement**
- 5.3.3.1.1 The ruggedized Platform Camera Assembly shall be placed around the vehicle to assist CHD operation as well as 360° view to give the crew comprehensive situational awareness on the battlefield.
- 5.3.3.1.2 The Platform Camera Assembly shall be able to provide 360 degrees field-of-view (FOV) around the vehicle in both day and night.

CO_CONFIDENTIAL

Page 38 of 80

CO_CONFIDENTIAL

- 5.3.3.1.3 The Platform Camera Assembly shall capture and transmit the video at 30 frames per second.
- 5.3.3.1.4 The Platform Camera Assembly shall consist minimally a compact Detector Thermal Imager (TI) that operates in the LWIR spectral region, a Full High Definition (FHD) Day Camera.
- 5.3.3.1.5 The Platform Camera Assembly shall allow view around the vehicle with a maximum dead ground of 3m. It must also be able to view a subject positioned at a height of 6m, 10 m away.
- 5.3.3.1.6 The Platform Camera Assembly shall allow identification of armed personnel of 1.6m in height, 50m away in daylight and 30m away under starlight conditions.
- 5.3.3.1.7 Contractor shall propose the numbers of Platform Camera Assembly including the numbers of Day and TI in the assembly required to be installed around the vehicle to achieve 360° degrees field-of-view (FOV) around the vehicle in both day and night.
- 5.3.3.1.8 Contractor shall provide the Platform Camera Assembly layout with Day and TI FOV coverage, hardware architecture, dead zone calculation, Detection, Recognition and Identification (DRI) calculation, Day and TI stitched image (mechanically or software stitched) in the proposal.
- 5.3.3.1.9 The Day and TI cameras are paired together to provide the following video outputs and are controlled via Ethernet:
- HD-SDI (DAY)
 - HD-SDI (TI)
 - HD-SDI (Fused Image)

CO_CONFIDENTIAL

CO_CONFIDENTIAL

- 5.3.3.1.10 The Platform Camera Assembly shall allow fusion of both Day and TI images.
- 5.3.3.1.11 Air and water nozzles directed at the windows shall be built into the Platform Camera Assembly to clean all the camera windows in the event that water, sand or mud obstructs the view.
- 5.3.3.1.12 The nozzles shall be designed and orientated such that the water and air blasts is able to cover the entire window area of the camera.
- 5.3.3.1.13 The Contractor shall cater 1x water and 1x air inputs in accordance to the interfaces specified in Figure 5:

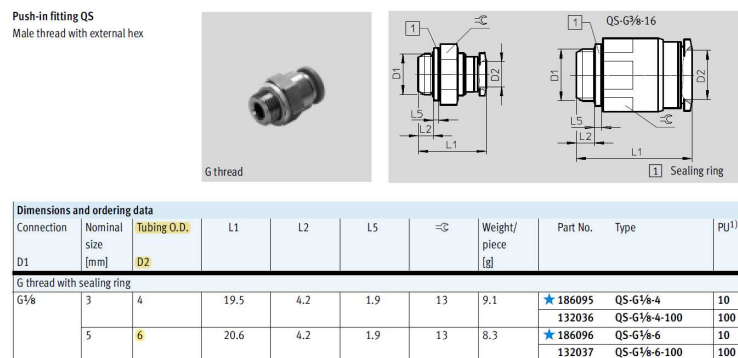

Figure 5: Air and Water Input Interface

- 5.3.3.1.14 The camera assembly view shall not be impaired by internal fogging. Internal glass and lens elements shall not fogged up under all conditions.
- 5.3.3.1.15 The Platform Camera Assembly shall receive the 1PPS signal from the video server to synchronize the video frames for video stitching algorithms and other high accuracy time synchronization application, if applicable.

5.3.3.2 Day Camera

- 5.3.3.2.1 The Day Camera shall meet the following design specification and requirements:

CO_CONFIDENTIAL

CO_CONFIDENTIAL

- 5.3.3.2.1.1 Effective Pixel shall be 1920 x 1080 and shall transmit at least 30 frames per second.
- 5.3.3.2.1.2 Synchronous operation when used with Day cameras & IMU, if applicable.
- 5.3.3.2.1.3 Min illumination shall be 0.05 Lux or better.
- 5.3.3.2.1.4 Signal to Noise Ration shall be greater than 50db.

5.3.3.3 TI Camera

5.3.3.3.1 The TI Camera shall meet the following design specification and requirements:

- 5.3.3.3.1.1 Effective Pixel shall be 640 x 480 or better and shall transmit at least 30 frames per second.
- 5.3.3.3.1.2 Video Polarity shall be White Hot (default)/ Black Hot.
- 5.3.3.3.1.3 Non-uniformity correction (NUC) shall be Auto / Manual.
- 5.3.3.3.1.4 NUC (Auto) shall notified the crew via OSD icon countdown
- 5.3.3.3.1.5 For NUC (Auto), countdown icon shall be white on colour and shall be displayed on the IDDP/UITs before triggering NUC (Auto) to warn the crew that the TI video image will be frozen momentarily.
- 5.3.3.3.1.6 Figure 6 shows the countdown icon on the display.

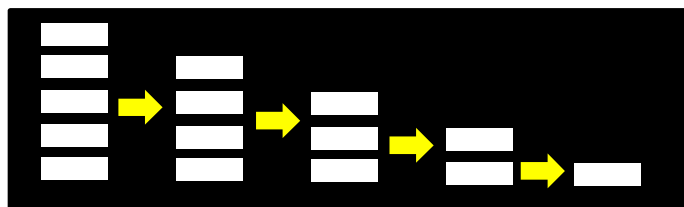



Figure 6: Countdown icon on the display

CO_CONFIDENTIAL

CO_CONFIDENTIAL

5.3.3.3.1.7 For NUC (Manual), a white triangular  icon shall be displayed on the IDDP/UITs to indicate that NUC (Manual) is being triggered.

5.3.3.3.1.8 Figure 7 indicate the location of the NUC icon on the IDDP/ UITs and Icon height shall not be larger than 10% of V.

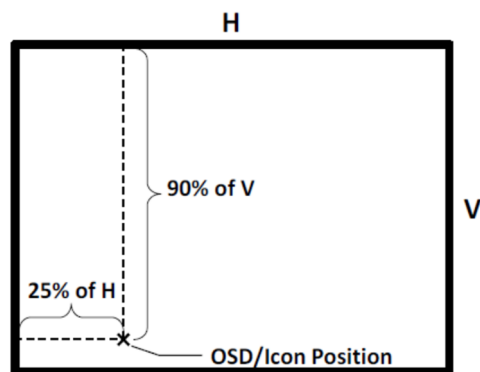

Figure 7: location of the NUC icon on the IDDP/ UITs

5.3.3.3.1.9 Availability of TI image to crew display shall be at least 15s or shorter.

5.3.3.3.1.10 Control Function for the TI shall include, but not limited to, TI NUC, TI White HOT or Black HOT.

5.3.3.4 Operating Power

5.3.3.4.1 The Platform Camera Assembly shall operate in compliance to Mil-Std 1275.

5.3.3.4.2 Contractor shall specify the nominal and maximum power consumption of the Platform Camera Assembly in the proposal.

5.3.3.4.3 Contractor shall provide the details function and specification of the Platform Camera Assembly software/ hardware to support the above requirements (e.g Interface PCB, Main Controller, GPU, Ethernet switch, FPGA, Power supplies and EMI filter etc).

CO_CONFIDENTIAL

CO_CONFIDENTIAL

5.3.4 Bird Eye View Cameras (BEV)

5.3.4.1 Bird Eye View cameras shall provide a top-down stitched view of up to 3.5m from the vehicle, with a desirable maximum radius of 5m from the vehicle's hull within acceptable distortion to identify human or obstacles at distances above 3.5m. This view will result in 0m of "deadground" around the vehicle at all times.

5.3.4.2 Bird Eye View Cameras are made up of 4 fisheye HD cameras to be mounted on the front, rear, left and right sides of vehicle. Location of the cameras on the vehicle shall be finalised during design review.

5.3.4.3 Effective Pixel shall be 1920 x 1080 or 1280 x 720p and shall transmit at maximum 30 frames per second.

5.3.4.4 Cameras are to be low-lux functional (visible down to 0.05Lux) and have FOVs equal to or greater than 180°.

5.3.4.5 Provision for overlays of ramp clearance zones and distance markers.

5.3.4.6 Allow for easy calibration of system on-board each vehicle.

5.3.4.7 Contractor shall provide the details function and specification of the Bird Eye View Cameras software/ hardware to support the above requirements (e.g Interface PCB, Main Controller, Electronics module, Power supplies and EMI filter etc).

5.3.5 Intelligent Driver Display Panel (IDDP)

5.3.5.1 The Intelligent Driver Display Panel (IDDP) is primarily used for closed-hatch driving and display information such as live video images captured from various cameras on the vehicle, navigation images as well as vehicle information such as vehicle speed and engine revolution speed etc.

CO_CONFIDENTIAL

CO_CONFIDENTIAL

- 5.3.5.2 The Video Server shall support failover criteria for HD-SDI to video LAN. Critical overlays and alerts such as pitch and roll indicator should be available on both paths (or done by IDDP).
- 5.3.5.3 The IDDP shall consist of 3 x LCD displays. The Contractor shall propose the maximum screen size that can be fit into the dimension given in Section 5.4.
- 5.3.5.4 The IDDP system shall be able to support overlay images (e.g flashing and still icons)
- 5.3.5.5 The IDDP system shall be able to support picture in picture.
- 5.3.5.6 The IDDP shall receive the vehicle data from in-vehicle networks (Can Bus).
- 5.3.5.7 The IDDP shall receive the video data from Video Server (Ethernet and HD-SDI).
- 5.3.5.8 The IDDP system shall not have terminating resistor (120 Ohm) between CAN H and CAN L.
- 5.3.5.9 The IDDP system shall have at least 6 buttons. Below are the preliminary buttons requirement.
- POWER Button
 - (+) Button for brightness adjustment
 - (-) Button for brightness adjustment
 - NUC Button
 - Fusion Button
 - Spare Button

CO_CONFIDENTIAL

Page 44 of 80

CO_CONFIDENTIAL

- iDDP power sequence:
 - Default: ON
 - To power OFF: Press POWER buttons for 1sec
 - To power ON: Press POWER buttons

5.3.5.10 Figure 8 shows the iDDP interface diagram.

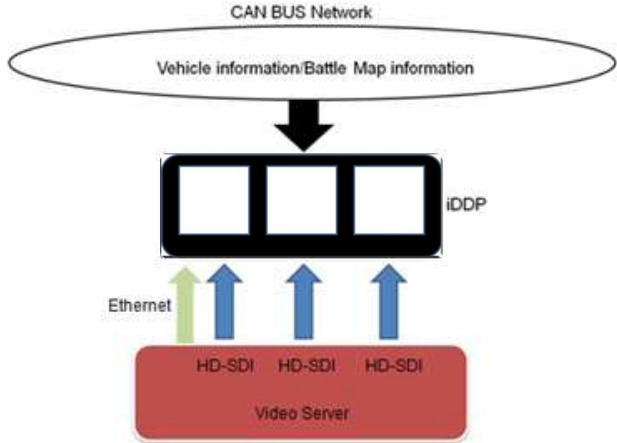

Figure 8: iDDP Interface Diagram

5.3.5.11 Figure 9 shows the preliminary buttons location.

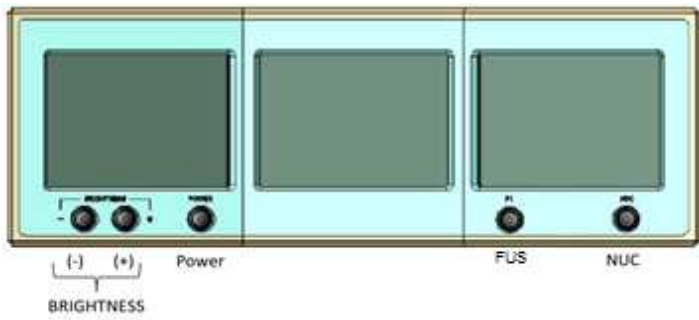

Figure 9: iDDP buttons and engraving location (to be finalized during design review)

CO_CONFIDENTIAL

CO_CONFIDENTIAL

5.3.5.12 Table 4 define the design specification and requirements for the IDDP.

Table 4: Design specification and requirements for the IDDP

No.	Description	Requirements	Remarks
Display			
5.3.5.12.1	Type & Size	Triple LCDs: The Contractor shall propose the maximum screen size that can be fit into the dimension given in Section 5.4.	-Hi-efficiency LED backlight. -All LCDs are optically bonded to one front glass
5.3.5.12.2	Resolution [H x V]	1920 x 1080 (FHD)	-
5.3.5.12.3	Luminance [ft-L]	Min. 200 (>680 cd/m2)	@60°C (Sun readable)
5.3.5.12.4	Contrast Ratio	800	Typical
5.3.5.12.5	Viewing Angles [°]	-80~+80 [H], -80~+80 [V]	Typical CR≥10. IPS technology
5.3.5.12.6	Pixel (LCD) Defects	No lit sub-pixels & no more than 3 unlit pixels	-
5.3.5.12.7	Line / Column Failures	On a blank or a white screen, there shall be no lines or columns or partial lines or columns that are lit or unlit inappropriately	-
5.3.5.12.8	Jitter	Jitter must be less than one pixel	-

CO_CONFIDENTIAL

Page 46 of 80

CO_CONFIDENTIAL

No.	Description	Requirements	Remarks
Display			
5.3.5.12.9	Motion Judder	Scan rate conversion 50i =>50p	-
5.3.5.12.10	Flicker	No visible flicker	-
5.3.5.12.11	Image Smearing	There shall be no significant image smearing when showing a typical moving image (after display warm-up in cold conditions).	-
5.3.5.12.12	Latency (HD-SDI)	Image latency shall not exceed 1.5 frames (~50ms).	-
User Interface			
5.3.5.12.13	Touch Panel	Capacitive touch panel	-
5.3.5.12.14	Buttons	up to 6	Located under side LCDs
Electrical Interfaces			
5.3.5.12.15	Nominal voltage	Vehicle 28V/24V DC (18-32Vdc)	Compliant to MIL-STD-1275B
5.3.5.12.16	Power Consumption	< 60 Watts	-

CO_CONFIDENTIAL

Page 47 of 80

CO_CONFIDENTIAL

No.	Description	Requirements	Remarks
Electrical Interfaces			
5.3.5.12.17	Connectors	D38999s on rear wall	To be defined during design review
5.3.5.12.18	Termination	CANH and CANL	No 120Ω resistor between CANH and CANL
5.3.5.12.19	Communications	-RS422 / RS485 -CAN Bus 2.0 A/B -10/100/1000 base T Ethernet	up to 921.6kbps (full duplex) according SAE J1939
Video & Graphics Capabilities			
5.3.5.12.20	Video Inputs	3 x HD-SDI 3 x HD-SDI (Spare)	The DC resistance value of all video inputs is 75Ω+/- 5Ω.
5.3.5.12.21	Features	- Video Scaling - On-Screen Display	API and SDK to be provided for software development.
General			
5.3.5.12.22	BIT	Sub-module isolation	-Power-up -Initiated -Periodic
5.3.5.12.23	Software update	Firmware or software	via Ethernet or RS232
5.3.5.12.24	Seam gap between LCD	The Contractor to propose the gap dimension between each LCD.	-

CO_CONFIDENTIAL

Page 48 of 80

CO_CONFIDENTIAL

- 5.3.5.13 The IDDP is the primary display for the driver under closed hatch driving, thus interruption to the video feed must be kept to the minimum.
- 5.3.5.14 The IDDP must synchronize with the switching video within 3 frames or less. This is to avoid display blackout when the driver switches video views.
- 5.3.5.15 Figure 10 shows the Overview IDDP Graphic User Interface for Left, Center and Right display.



Figure 10: Overview IDDP GUI for Left, Center and Right display

- 5.3.5.16 The Contractor shall provide the required tool and procedures to carry out OSD adjustment or programming including live calibration and adjustment of the OSD on the IDDP.

5.4 **Mechanical Requirements**

- 5.4.1 The Contractor shall fit the video server and its peripherals within the mechanical constraints of the platform as defined by the Buyer as indicated in Appendix H: Mechanical requirements of this specification document. The mechanical interface connection documents shall be provided in the proposal submission for assessment.
- 5.4.2 The final physical and ventilation envelopes of the Vision system shall not exceed the dimension in Appendix H- Mechanical Requirement and the physical mounting interfaces shall be deemed final in IR#1. Shall there be any changes to the mechanical interfaces and envelopes after IR#1 from Contractor, the Buyer shall

Page 49 of 80

CO_CONFIDENTIAL

CO_CONFIDENTIAL

reserve the right to recover the associated costs resulting from the need for Buyer to perform design changes and for any increase in production costs resulting from such changes.

5.4.3 Contractor is to provide a complete physical mockup of final envelope and interfaces replicating the actual hardware for form-fit checking to allow Buyer to perform physical interface design based on the schedule indicated in Appendix I.

5.4.4 Contractor shall work with Protection System Contractor to ensure successful integration of both Systems.

5.5 **Electrical Requirements**

5.5.1 The Contractor shall provide the connectors layout and part numbers of the Vision System hardware.

5.5.2 The positioning of the connectors shall also be of easy access for the user to plug and unplug of the mating connectors.

5.5.3 Those connectors that are not being connected or used. It shall be protected by dust cap with chain.

5.5.4 The positioning of the dust caps shall also be of easy access for the user to plug and unplug if there is a need to access the connector.

5.5.5 The Contractor shall provide the standby, nominal, peak, maximum current of the Vision System hardware in the proposal.

CO_CONFIDENTIAL

CO_CONFIDENTIAL

5.6 Configuration Management

- 5.6.1 Contractor shall implement a configuration management process to establish and maintain consistency between the product requirements, the product, and associated product configuration information.
- 5.6.2 Minor changes / modifications that are initiated by the Contractor without any implication of performance, schedule and cost of the project; Buyer shall be informed in writing. The configuration information (drawings, document deliverables, BOM, training materials, etc) affected by the change shall be updated and provided to Buyer.
- 5.6.3 For major changes that impact the form, fit, function or any changes that affect the product inter-changeability (including technical publications, logistics support, STEs) with its previous revision, a request shall be submitted to Buyer for approval prior to the change implementation.
- 5.6.4 For critical changes that results in functional or performance deviation from the original requirements or affects schedule and costs, a proposal shall be submitted to Buyer for approval.
- 5.6.5 The Contractor shall assist in the verification of the Vision System Architecture interconnection. In the event, the Vision System do not meet the requirements, the Contractor shall propose alternatives or changes, subjected to the approval of Buyer.
- 5.6.6 The Contractor shall also conduct regular design review sessions with Buyer until the final approval is given by Buyer for the building of the Vision System hardware.

CO_CONFIDENTIAL

Page 51 of 80

CO_CONFIDENTIAL

5.6.7 Each Vision System hardware shall be serialized in accordance to the following format:

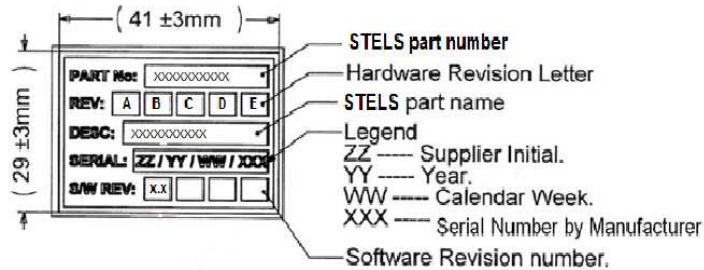

5.6.8 The Contractor shall consider the simplicity of update of hardware and software revision on label for future update by Buyer.

5.6.9 The Contractor shall provide an aluminum plate serial label and Contractor are allow to propose an alternate label but subjected to Buyer approval.

5.6.10 The Contractor shall print REV: A to E and S/W REV: 1 to 4 according to Section 0 and shall dot punch according to the revision release (Example REV:Ⓐ and S/W REV: ①).

5.6.11 The Contractor shall provide the location of the serial plate in the proposal.

5.6.12 The Contractor shall conduct a serial plate review sessions with Buyer until the final approval is given by Buyer.

5.7 **EMI / EMC and Operating Voltage Requirement**

This section identifies the EMI / EMC and Operating Voltage Requirement.

5.7.1 **Applicable Documents**

The following military / industrial standards (or equivalent) are applicable to this program:

CO_CONFIDENTIAL

CO_CONFIDENTIAL

- 5.7.1.1 MIL-STD-461E: Requirements for Electromagnetic Interference Characteristics
- 5.7.1.2 MIL-STD-464C: Electromagnetic Environmental Effects Requirements for Systems
- 5.7.1.3 MIL-STD-1275B: Characteristics of 28 Volt DC Electrical Systems in Military Vehicles
- 5.7.1.4 MIL-STD-188-124B: Grounding, Bonding and Shielding for common long haul/tactical communication system including ground base communication, electronic facility and equipment
- 5.7.1.5 IEC-61000-4-2: International Standard Testing and Measurement Techniques
Other Equivalent Testing Standards, if any

5.7.2 EMI / EMC Requirements

- 5.7.2.1 The System shall meet but not limited to the following EMC requirements:
 - CE 102 (Conducted emissions, power leads, 10 kHz to 10 MHz)
 - RE 102 (Radiated emissions, electric field, 2 Khz to 18 GHz)
 - CS101 (Conducted susceptibility, power leads, 30 Hz to 150 kHz)
 - CS114 (Conducted susceptibility, bulk cable injection, 10 kHz to 200 MHz)
 - CS115 (Conducted susceptibility, bulk cable injection, impulse excitation)
 - CS116 (Conducted susceptibility, damped sinusoid transients, cables and power leads, 10 kHz to 100MHz)
 - RS103 (Radiated susceptibility, magnetic fields, 2 MHz to 18 GHz)
- 5.7.2.2 The system shall be qualified to MIL-STD-461E (Ground Army).

Page 53 of 80

CO_CONFIDENTIAL

CO_CONFIDENTIAL

- 5.7.2.3 If any sub-system or module deviates from MIL-STD-461E specification limits or complies with standards other than MILSTD-461E, the Contractor is to submit a waiver analysis report to seek for waiver approval from Buyer.
- 5.7.2.4 The System EMI qualification reports shall be provided.
- 5.7.2.5 The Electromagnetic Interference (EMI) level of the System, including all connecting cables, shall be established and provided to Buyer. The Contractor shall describe the test plan and its results, conforming to MIL-STD-831 (or equivalent).
- 5.7.2.6 Non-Development items (NDI) and Commercial Items. The Supplier shall ensure that the NDI and commercial items, selected by the Supplier shall fulfil the contractual EMI requirement. The Supplier shall ensure necessary EMI control measures on the NDI and commercial items to meet its contractual EMI requirement. NDI and commercial items shall meet EMI interface control requirements suitable for ensuring that system operational performance requirements are met. Compliance shall be verified by test, analysis, or a combination thereof. Any non-compliance shall be submitted to Buyer for waiver.
- 5.7.2.7 **Grounding and Bonding**
- The Contractor shall ensure proper grounding for the subsystems or electronic modules to control EMI and electrical safety. The rationale for using single point, multiple point or hybrid grounding shall be provided. The techniques of bonding shall be described.

CO_CONFIDENTIAL

Page 54 of 80

CO_CONFIDENTIAL

5.7.2.8 Shielding

The sub-systems or modules shall have adequate shielding from electric field and magnetic field interference, by means of shielded enclosure. The shielding requirement and rationale for shielding should be provided.

5.7.2.9 Filtering

The sub-systems or modules shall have adequate filtering by means of power line filter and signal line filter to prevent interference. The filtering requirement and rationale for filtering shall be provided.

5.7.2.10 Cabling

Cables types and routing shall be selected to ensure that cable coupling from nearby cables as well as from radiated electric and magnetic field is minimum and will not affect the operation of the sub-systems or modules link by these cables.

5.7.2.11 Life Cycle E3 Hardness.

The Contractor shall fulfil the requirements of a life cycle E3 Hardness analysis to show that the sub-systems or modules meet the Life Cycle E3 Hardness requirements of MIL-STD-464C. The analysis may be based on inspections of maintenance manuals that show electrical bonding procedures comply with life cycle E3 hardness requirements including measurement of critical electrical bonds at specified intervals.

5.7.2.12 Printed Circuit Board and Components

Conformal coating shall be required for printed wiring and multi-layer board in accordance with MIL-STD-454 (or equivalent). Connectors and fastening devices shall be of high corrosion resistance grade to resist the worst environment that the System may encounter.

Page 55 of 80

CO_CONFIDENTIAL

CO_CONFIDENTIAL

5.7.2.13 Documentation Requirements:

The EMC of the sub-system and electronic module shall be established and the following documents shall be provided by the Contractor:

- a. EMC Control Plan
- b. EMC Test Plan/Procedure
- c. EMC Test Report

5.7.2.13.1 EMC Control Plan (EMCCP)

5.7.2.13.1.1 The Contractor shall provide a preliminary copy of the EMC control plan (EMCCP) to Buyer not more than 1 month after contract signature. Thereafter, the Contractor shall refine and update the Control Plan accordingly at the request of the Buyer. The final version shall be given to Buyer for approval at least three (3) months before Production Design Update (PDU) or Critical Design Review (CDR).

5.7.2.13.1.2 EMCCP shall cover grounding, bonding, shielding, filtering etc and the relevant parameters to ensure that the sub-systems or modules meet EMC requirements.

5.7.2.13.1.3 The Contractor shall describe the approach taken to ensure compliance to EMC during the design review. The review may cover the following areas:

- a. Component selection
- b. Best practices adopted
- c. Design approach

5.7.2.13.2 EMC Test Plan (EMCTP)

5.7.2.13.2.1 The Contractor shall provide the preliminary EMC Test Plan (EMCTP) to Buyer for evaluation.

Page 56 of 80

CO_CONFIDENTIAL

CO_CONFIDENTIAL

- 5.7.2.13.2.2 The Contractor shall provide the final EMCTP to the Buyer for review and approval at least 2 months prior to the commencement of the tests.
- 5.7.2.13.2.3 Degradation criteria shall be included in the EMCTP and submitted to the Buyer for evaluation and approval.
- 5.7.2.13.2.4 The EMC Test Plan shall include the purpose of each measurement, the measurement procedures, the data recording format and the list of equipment. The EMCTP, including EMC test procedure shall also contain the contents listed in Appendix A.
- 5.7.2.13.2.5 The sub-system or module function procedures shall be included in the EMCTP.
- 5.7.2.13.3 EMC Test Report (EMCTR)
- 5.7.2.13.3.1 The Contractor shall provide a complete EMCTR describing the EMCTP and its results, conforming to MIL-STD-831 (or equivalent).
- 5.7.2.13.3.2 The report shall contain complete information on all applicable tests and other information as required.
- 5.7.2.13.3.3 Data analysis, interpretation of results as well as recommendations for EMI solution for problems encountered during tests shall be provided. The EMCTR shall also contain the contents listed in Appendix A.

5.7.3 Power Requirements

- 5.7.3.1 This section specifies the performance of the sub-system or module (Electrical Device Under Test; EDUT) when subjected to the electrical voltage operating requirements of MIL-STD-1275B.
- 5.7.3.2 The Contractor shall design the System to meet MIL-STD-1275B requirements pertaining to operating voltages and voltage spikes/surges.

Page 57 of 80

CO_CONFIDENTIAL

CO_CONFIDENTIAL

- 5.7.3.3 The Contractor is to comply with the paragraph “Vehicle Equipment” requirement (paragraph 5.4.2 of MIL-STD-1275B) that the EDUT shall not malfunction or have any unacceptable response with the application of the operating voltage.
- 5.7.3.4 The EDUT shall be subjected to operating voltage surges from both normal mode and generator-only mode. It shall also be subjected to voltage spikes with sufficient energy content to test the EDUT response.
- 5.7.3.5 The EDUT shall be subjected to ripple voltages between 23V and 33V imported into it. It shall demonstrate indefinite immunity to ripple voltages over the frequency range of 50 Hz to 200 kHz.
- 5.7.3.6 The EDUT shall be monitored for voltage spikes exported over the operating voltage range. The EDUT shall be operating over its specific range of functions, including powering on and off.
- 5.7.3.7 The EDUT shall not malfunction or have any unacceptable response with the application of the operating voltage within a voltage range of +18 VDC to +32 VDC, where the applied nominal voltage is 28 VDC. Operating time (minimum 10 minutes) at various voltage levels (18V, 20V, 24V, 28V, 30V and 32V) is recommended.
- 5.7.3.8 The EDUT shall have necessary protection against power supply reverse polarity.
- 5.7.3.9 The EDUT shall not malfunction or have any unacceptable response with the application of the operating voltage profile corresponding to “Initial Engagement Surge” (IES; paragraph 3.1.7, Figure 3). In the event that the EDUT cannot meet the IES profile in Figure 3, the Contractor shall establish the minimum IES level and duration which the EDUT can operate without malfunction or have any unacceptable response.
- 5.7.3.10 The Contractor shall support the MIL-STD-1275B testing with suitable testers and test cabling.

Page 58 of 80

CO_CONFIDENTIAL

CO_CONFIDENTIAL

5.7.3.11 Documentation Requirements**5.7.3.11.1 Test Plan (TP)**

5.7.3.11.1.1 The Contractor shall provide a Test Plan (TP) to demonstrate the EDUT performance when subjected to MIL-STD-1275 operating voltage.

5.7.3.11.1.2 The preliminary TP shall be provided to Buyer for evaluation two months before the commencement of the tests.

5.7.3.11.1.3 The final Test Plan shall be submitted to Buyer for review and approval at least 2 weeks prior to commencement of the tests.

5.7.3.11.2 Test Report (TR)

5.7.3.11.2.1 The Contractor shall provide a complete Test Report (TR) describing the TP and its results. The report shall contain complete information on all applicable tests and other information as required. Data analysis, interpretation of results as well as recommended for solution for problems encountered during tests shall be provided.

5.7.3.11.2.2 The TR shall be provided to STK one (1) month after completion of test.

5.8 Environment Requirements

This section outlines the Environmental Qualification Test (EQT) requirement for Vision System in meeting the environmental conditions (typical South East Asia climatic conditions) during operation and storage without experiencing physical damage or deterioration in performance. The Vision System is referred to as the system in this section.

5.8.1 Applicable Documents

MIL-STD 810E Environmental Test Methods and Engineering Guidelines

Page 59 of 80

CO_CONFIDENTIAL

CO_CONFIDENTIAL

IEC 60529	Degree of Protection provided by Enclosures (IP Code).
STANAG 2895	Extreme Climatic Conditions and Derived Conditions for use in Defining Design / Test Criteria for NATO Forces Material

Other equivalent testing standards, if any.

5.8.2 Responsibilities of Contractor

- 5.8.2.1 Contractor may utilise the referenced test profiles from Table 5 to Table 9 for development of the System.
- 5.8.2.2 For vibration qualification, the Contractor shall perform qualification of the Systems based on the final vibration test profiles provided after finalisation of the location, interfaces, weight and dimensions of Systems and brackets after actual measurement performed.
- 5.8.2.3 For the system that has been previously qualified, the Contractor shall provide Certificate of Conformance (COC) to Buyer. The relevant test reports or technical specifications shall also be submitted to Buyer for verification.
- 5.8.2.4 In the event that the proposed equipment is unable to meet the environmental requirements as stated in Table 5 to Table 9 . The Contractor shall make good design and conduct tests based on test requirements as specified in this document. Test reports shall be submitted to Buyer for verification.
- 5.8.2.5 For the equipment which environmental tests have not been performed, the Contractor shall conduct tests and test reports shall be submitted to Buyer for verification.

CO_CONFIDENTIAL

Page 60 of 80

CO_CONFIDENTIAL

5.8.2.6 It is the responsibility of the Contractor to manufacture the system according to the specifications as indicated in the test reports/ catalogues.

Table 5: Environmental Qualification Test Profile

System Test	Requirements	Test Standard and Methods	Duration
High Temperature (Temperature will be higher if equipment is located in the engine bulkhead)	Max Operating Temperature for Server = 65°C	MIL-STD 810E, Method 501.3, Proc II, Table 501.3-I capped at 65°C	24Hr X 3 Cycles (operational)
	Max Operating Temperature for the rest of Vision System hardware = 55°C	MIL-STD 810E, Method 501.3, Proc II, Table 501.3-I capped at 55°C	24Hr X 3 Cycles (operational)
	Max storage Temperature = 71 °C	MIL-STD 810E, Method 501.3, Proc I ,Table 501.3-II (Induced condition)	24Hr X 7 Cycles (storage)
Low Temperature	Operating Temperature = -10°C	MIL-STD 810E, Method 502.3, Proc II, with minimum 5 hours at -10°C	1 Cycle (operational)
	Storage Temperature = -21°C	MIL-STD 810E, Method 502.3, Proc I, with detailed profile in STANAG 2895 (Induced air temp at C0) as in Table A-2	24Hr X 3 Cycles (storage)

CO_CONFIDENTIAL

CO_CONFIDENTIAL

System Test	Requirements	Test Standard and Methods	Duration
Humidity	Shall maintain the specified performance when exposed to the humidity in its operating and non-operating state for continuous periods, including conditions wherein condensation takes place in and on the equipment in the form of water. Fogging on the inside of the cover glass of the instrument panel and gauges shall not occur.	MIL-STD 810E - Method 507.3, Figure 507.3-3	24Hr X 10 Cycles
Solar Radiation (only for camera which are directly exposed to sunlight)	1120W/m ² at 49°C	MIL-STD 810E, Method 505.3, Proc II	10 days
Fungus (for material may generate Fungus)	Resistant to fungus growth.	MIL-STD 810E - Method 508.4	28 Days
Salt Fog	Protect against effects of salt laden atmosphere	MIL-STD 810E, Method 509.3, Proc I	(1 cycle (Wet) and 1 cycle(Dry)) X 2 times, total of 4 cycles: 96 Hrs 1cycle: 24 Hrs

CO_CONFIDENTIAL

CO_CONFIDENTIAL

System Test	Requirements	Test Standard and Methods	Duration
Vibration	Tracked vehicle vibration profile	Reference Profiles as in Table 7 to Table 9 (Final test profile will be provided by Buyer based on measured profile after finalization of interface and component specifications by Contractor)	One axis 270 minutes, total 810 minutes for three axis (operating configuration)
Shock	Mobility shock (40g/11ms, saw tooth)	MIL-STD 810E, Method 516.4, Proc I, 6 shocks for each axis including positive and negative. Total, 18 shocks	40g@11msec, 6 shock for each axis including positive and negative. Total of 18 shocks. (operating configuration)
Corrosion	Design to withstand corrosion, especially Uniform Attack, Galvanic Corrosion, Crevice Corrosion	Qualified by Analysis with material selection	NA
Contamination	The equipment shall perform without degradation exposure to contaminating fluids such as (a) Petrol and diesel fuel (b) Hydraulic fluid (c) Engine and gearbox oil (d) Fire extinguishing fluid	MIL-STD 810G, Method 504.1, Proc I, Table 504.1-1 (Fuels, Hydraulic oils, Lubricating oils, Fire extinguish fluid, etc.) Fluid Type: To be confirmed with Buyer	1 Cycle (24 Hrs):8 Hrs of Chemical contact and 16 Hrs of drying period, total: 3 Cycles (3 X 24 Hrs)

CO_CONFIDENTIAL

CO_CONFIDENTIAL

System Test	Requirements	Test Standard and Methods	Duration
Dust	Withstand air containing dust.	IEC 60529, IP6X	Refer to IEC 60529 IP6X: 2hrs for each equipment if the extraction rate of 40-60 vol. per hr is achieved until 80 volumes have been through or a period of 8 hrs. (with under pressure of 2KPa)
Water	Withstand the effects of rain in its operating and non-operating state	IEC 60529 IPX6 (for equipment located outside vehicle), IPX5 (for equipment located inside vehicle)	Refer to IEC 60529 Minimum: 3mins for each equipment

Table 6: Environmental Qualification Test profile for Low Temperature storage

CO CYCLES for Material

Local Time	Meteorological Conditions			Storage and Transit Conditions	
	Ambient Air Temp	Relative Humidity	Solar Radiation	Induced Air Temp	Relative Humidity
h	°C	%	W/m ²	°C	%
0300	-19	} Tending to saturation	} Negligible on days when accompanying temperatures occur	-21	} Tending to saturation
0600	-19			-21	
0900	-15			-19	
1200	-8			-12	
1500	-6			-10	
1800	-10			-14	
2100	-17			-19	
2400	-19			-21	

CO_CONFIDENTIAL

CO_CONFIDENTIAL

Table 7: Vibration Profile for equipment at Right Sponson

Test duration per axis: 270 minutes per 6000 miles

Test Phase	5-500 Hz Floor Level (g ² /Hz)	No. Sweeps	Narrowband 1			Narrowband 2			Narrowband 3			Narrowband 4			Narrowband 5		
			Bw (Hz)	Ampl (g ² /Hz)	Sweep BW (Hz)	BW (Hz)	Ampl (g ² /Hz)	Sweep BW (Hz)	BW (Hz)	Ampl (g ² /Hz)	Sweep BW (Hz)	BW (Hz)	Ampl (g ² /Hz)	Sweep BW (Hz)	BW (Hz)	Ampl (g ² /Hz)	
VERTICAL AXIS (45 minutes per test phase)																	
VO1	0.0056	4	24-30	0.1523	3	48-60	0.0844	6	72-90	0.1025	9	96-120	0.0226	12	120-150	0.0123	15
VO2	0.0120	4	36-42	0.3098	3	72-80	0.5120	6	108-126	0.0938	9	144-168	0.0736	12	180-210	0.0908	15
VO3	0.0132	2	48-60	1.0	6	96-120	0.2508	12	144-180	0.1737	18	192-240	0.1615	24	240-300	0.1143	30
VO4	0.0110	2	67-68	2.0	6	132-156	0.1573	12	198-234	0.1719	18	264-312	0.0613	24	330-390	0.0549	30
VO5	0.0180	2	84-102	1.0	9	168-204	0.5375	18	252-306	0.3000	27	336-408	0.1212	36	420-500	0.1134	45
VO6	0.0208	3	108-120	1.0	6	216-240	1.1798	12	324-360	0.6259	18	432-480	0.2177	24	-----	-----	--
TRANSVERSE AND LONGITUDINAL AXIS (45 minutes per test phase)																	
TO1	0.0075	4	24-30	0.0238	3	48-60	0.1397	6	72-90	0.2698	9	96-120	0.0601	12	120-150	0.0358	15
TO2	0.0149	4	36-42	0.2406	3	72-84	1.2746	6	108-126	1.0559	9	144-168	0.2446	12	180-210	0.1039	15
TO3	0.0152	2	48-60	1.0	6	96-120	1.0347	12	144-180	0.4844	18	192-240	0.1891	24	240-300	0.1900	30
TO4	0.0124	4	66-72	1.0	3	132-144	0.3121	6	198-216	0.1896	9	264-288	0.0858	12	330-360	0.0498	15
TO5	0.0098	2	84-102	1.0	9	168-204	0.3376	18	252-306	0.4768	27	336-408	0.0833	36	420-500	0.0386	45
TO6	0.0234	3	108-120	1.0	6	216-240	0.6378	12	324-360	0.6412	18	432-480	0.1028	24	-----	-----	--

Table 8: Vibration Profile for Camera on Top Deck

Test duration per axis: 270 minutes per 6000 miles

Test Phase	5-500 Hz Floor Level (g ² /Hz)	No. Sweeps	Narrowband 1			Narrowband 2			Narrowband 3			Narrowband 4			Narrowband 5		
			Bw (Hz)	Ampl (g ² /Hz)	Sweep BW (Hz)	BW (Hz)	Ampl (g ² /Hz)	Sweep BW (Hz)	BW (Hz)	Ampl (g ² /Hz)	Sweep BW (Hz)	BW (Hz)	Ampl (g ² /Hz)	Sweep BW (Hz)	BW (Hz)	Ampl (g ² /Hz)	
VERTICAL AXIS (45 minutes per test phase)																	
VO1	0.0057	4	24-30	0.3166	3	48-60	0.0571	6	72-90	0.2471	9	96-120	0.0284	12	120-150	0.0253	15
VO2	0.0101	4	36-42	0.3222	3	72-84	0.4779	6	108-126	0.1729	9	144-168	0.2408	12	180-210	0.0902	15
VO3	0.0136	2	48-60	0.5418	6	96-120	0.3462	12	144-180	0.3483	18	192-240	0.4488	24	240-300	0.1387	30
VO4	0.0104	2	66-78	0.5959	6	132-156	0.2800	12	198-234	0.1679	18	264-312	0.0208	24	330-390	0.0349	30
VO5	0.0164	2	84-102	4.0698	9	168-204	0.8382	18	252-306	0.0992	27	336-408	0.0621	36	420-500	0.0214	45
VO6	0.0254	3	108-120	4.0	6	216-240	3.0643	12	324-360	0.2433	18	432-480	0.0608	24	-----	-----	--
TRANSVERSE AND LONGITUDINAL AXIS (45 minutes per test phase)																	
TO1	0.0018	4	24-30	0.0582	3	48-60	0.0153	6	72-90	0.0305	9	-----	-----	--	120-150	0.0029	15
TO2	0.0033	4	36-42	0.1131	3	72-84	0.0460	6	108-126	0.0300	9	144-168	0.0137	12	180-210	0.0095	15
TO3	0.0049	2	48-60	0.4060	6	96-120	0.0803	12	144-180	0.0262	18	192-240	0.0390	24	240-300	0.0283	30
TO4	0.0032	3	66-78	0.3632	6	132-156	0.0192	12	198-234	0.0104	18	264-312	0.0030	24	-----	-----	--
TO5	0.0067	2	84-102	0.7592	9	168-204	0.0891	18	252-306	0.0568	27	-----	-----	--	-----	-----	--
TO6	0.0063	4	108-120	2.0	6	216-240	0.1276	12	324-360	0.0511	18	-----	-----	--	-----	-----	--

CO_CONFIDENTIAL

CO_CONFIDENTIAL

Table 9: Vibration Profile for IDDP at Driver Station

Wideband Random Spectrum		Harmonic Sweep Narrowband				Grms of Narrow Band	Total Grms	
5	0.001	Narrow Band	f1	f2	f3			3.5
8	0.01	Bandwidth, Hz	5	10	15			
120	0.01	Sweep Bandwidth, Hz	16-120	32-240	48-360			
500	0.01	Vertical, Transverse & Longitudinal(g ² /Hz)	1	0.4	0.2	3.5	4.1	
Grms of Broadband	2.22							

Vibration duration: 120 minutes / axis

No of axis: 3 axes

Note:

The vibration profiles proposed here are for equipment rigidly mounted on AFV and modified from Table 514.4, AXVI, M113 at Sponson and Table 514.4, AXVII, M113 at Top.

It should be noted that the profiles here are for REFERENCE ONLY. The final test profiles shall be generated based on the measurement at the actual mounting locations of equipment on vehicle together with their mounting bracket if any.

5.8.3 Test Requirements

5.8.3.1 A list of the test requirements with the required test standards and methods is provided in this document.

5.8.3.2 In the event that the test standards employed are different from the requirements as stated in this document, the Contractor shall explain the differences and provide justifications that they are equivalent or better.

CO_CONFIDENTIAL

CO_CONFIDENTIAL

5.8.4 Requests for Waiver

5.8.4.1 For the equipment that has been deployed in the similar or worse environmental conditions as stated in this section and the Contractor intends to request for waiver of tests, the Contractor shall minimally provide justification as shown in Table 10 to Buyer for consideration.

Table 10: Justification for Environmental Qualification

Name of Test	Required Test Level	Product Spec.	Justification
E.g High Temp. (Operating)	Contract requirement. E.g. 55 degree	Product specifications. E.g. No spec	E.g. Has been used in xxx vehicle, which is in the Climatic Conditions of Singapore (A2 Conditions as defined in STNAG 2895).
E.g Salt Fog Test	Contract requirement. E.g. Protect against effects of salt laden atmosphere	Product specifications. E.g. No spec	E.g. This box is made of Anodized Aluminum, which is resistant to Corrosion like salt fog

5.8.4.2 It is the Contractor's responsibility to provide as much information as possible on the waiver justifications to Buyer for consideration.

5.8.4.3 Buyer shall have the right to verify the Contractor claims by conducting verification testing if necessary. In the event that the results are not satisfactory, the Contractor shall be responsible to make good the design in order to meet the requirements as indicated in this document.

5.8.4.4 In the event that request for waiver of test is not accepted, the Contractor shall be responsible to conduct the test as stated in Table 5.

CO_CONFIDENTIAL

CO_CONFIDENTIAL

5.9 Safety Requirements

This section defines and describes the Safety Requirements of the Video Server.

5.9.1 Applicable Documents

Document Prefix	Document Description
MIL-STD-882E	Standard Practice for System Safety
AMCP 706-125	Engineering Design Handbook, Electrical Wire and Cable
MIL-HDBK-454B	General Guidelines for Electronic Equipment, Department of Defence Handbook

Any other equivalent standards, if any.

5.9.2 Excessive Temperature

5.9.2.1 Requirements are included to prevent injury due to excessive temperatures of accessible parts, to prevent damaging of insulation due to excessive internal temperatures, and to prevent mechanical instability due to excessive temperatures developed inside the Vision System Hardware.

5.9.2.2 Table 11 shows the permissible temperature that should not exceed at all times during operation under ambient temperature of 25 degrees Celsius.

CO_CONFIDENTIAL

CO_CONFIDENTIAL

Table 11: Permissible temperature rise of the parts of the Vision System hardware

Permissible Temperature Rise of parts of Vision System hardware		
Parts of Vision System hardware	Normal Operating Temp, K	Fault Conditions, K
Accessible Parts Knobs, Handles, etc - Metallic	30°C	65°C
	50°C	65°C
Enclosure if - Metallic	40°C	65°C
	60°C	65°C

5.9.2.3 Wiring

5.9.2.3.1 When selecting wiring for vehicular electrical systems, consideration must be given to high physical strength, high temperature resistance, high dielectric and high abrasion resistance. Refer to Chapter 8 and to AMCP 706-125, Engineering Design Handbook, Electrical Wire and Cable for wire selection and cable design. Also refer to MIL-HDBK-454B, General Guidelines for Electronic Equipment, Department of Defence Handbook.

5.9.2.3.2 Specify frequent wiring supports to prevent chafing and free end of a broken wire from contacting grounded metal surfaces. Protection can be achieved with heavy duty binding or jacket material over wire bundle. Wiring used must be able withstand high physical strength, high temperature resistance, high dielectric and high abrasion resistance.

5.9.2.4 Mechanical Hazard

5.9.2.4.1 Requirements are included to ensure that the Vision System hardware and its parts have adequate mechanical strength and stability.

CO_CONFIDENTIAL

CO_CONFIDENTIAL

5.9.2.4.2 The Vision System hardware must also be free from the presence of sharp edges. Refer to MIL-HDBK-454B, General Guidelines for Electronic Equipment, Department of Defence Handbook.

5.9.2.5 Fire

Material used in the construction of the Vision System hardware should not be flammable or support the fire where applicable.

5.9.3 System Safety Requirements for Software

5.9.3.1 Video Server and IDDP is identified to have Software Criticality Index 1 (SwCI 1) for the following hazards:

- a. Driver/ Commander misled by wrong camera video display
- b. Loss of video display during closed hatch driving

5.9.3.2 The Contractor is required to conduct the analysis or testing as listed in Appendix B: Software Safety Requirements of this specification document.

5.9.4 Safety Critical Item (SCI) and Reliability Critical Items (RCI)

5.9.4.1 Safety Critical Items

In the event of safety critical path, there shall be two discrete components and it shall not be of same type and same brand within the same circuit.

5.9.4.2 Reliability Critical Items

5.9.4.2.1 Video Server, IDDP, BEV Cameras and Platform Cameras (Driving Camera) are classified as Reliability Critical Item.

CO_CONFIDENTIAL

Page 70 of 80

CO_CONFIDENTIAL

5.9.4.2.2 100% Acceptance Functional Check to be carried out for Video Server, IDDP, BEV Cameras and Platform Cameras (Driving Camera).

5.10 **Acceptance Requirements**

This section defines and describes the Acceptance Requirements of the Vision System hardware

5.10.1 **General**

5.10.1.1 This section stipulates the formal acceptance tests required for the Vision System hardware. Acceptance tests shall be carried out by the Contractor to verify that the Vision System hardware conforms to its specifications and requirements in this document.

5.10.1.2 It should be noted that the successful completion of these acceptance tests themselves do not necessarily constitute delivery or sell-off. The acceptance tests are necessary proof to show that the Vision System hardware meets specifications and requirements. The successful completion of the tests shall form a necessary criterion for delivery.

5.10.1.3 The tests stipulated here shall form the minimum tests required for this Vision System hardware. The Contractor may, at her own professional discretion, propose to carry out additional tests to ensure that the Vision System hardware meets its specifications subjected to Buyer approval.

5.10.1.4 On Vehicle acceptance tests shall be carried out in Singapore in accordance with the approved Acceptance Test Procedure and in the presence of Buyer' personnel.

CO_CONFIDENTIAL

Page 71 of 80

CO_CONFIDENTIAL

5.10.1.5 For each Acceptance Test, an acceptance test certificate shall be issued only when all of the following are satisfied:

- a. Successful completion of all Acceptance Tests as specified herein and in accordance with the applicable Acceptance Test Criteria / Procedure.
- b. Submission of all documentation reflecting the successful completion of all In-Process and Acceptance tests.

5.10.2 In-Process Inspection & Testing

5.10.2.1 The Contractor shall perform, as part of its quality control process, a series of formal and documented in-process inspection and testing prior to start of any acceptance testing. The In-Process Inspection and Testing will cover the sub-assembly, assembly and system level.

5.10.2.2 The test plans, procedures and the results of the In-Process Inspection and Testing will be provided to Buyer for review. The Buyer representatives will be informed and invited to the In-Process Testing so as to provide Buyer the visibility into the progress and status of the program.

5.10.3 Type of Acceptance Tests

5.10.3.1 The Contractor shall work, manage, co-ordinate, perform and certify the acceptance tests specified in Section 5.10.3.4.

5.10.3.2 The acceptance tests shall be conducted in accordance with the Acceptance Test Procedures approved by Buyer.

5.10.3.3 The Contractor shall also provide the necessary equipment, logistics and resources for carrying out the relevant tests.

CO_CONFIDENTIAL

CO_CONFIDENTIAL

- 5.10.3.4 The Acceptance Tests shall include, but not limited to the following:
- a. EMI / EMC Qualification Test (see details of requirements in Section 5.7)
 - b. Environment Qualification Test (see details of requirements in Section 5.8)
 - c. Factory Acceptance Test (FAT)
 - d. On Vehicle Acceptance Test (Support in acceptance test)
- 5.10.3.5 Factory Acceptance Test proposed by the Contractor shall include but not limited to the following inspection for the camera lens:
- 5.10.3.5.1 Workmanship criteria for Electronic equipment
- MIL-HDBK-454B, Workmanship guideline 9
- 5.10.3.5.2 Edge cement defects
- MIL-PRF-13830B, PERFORMANCE SPECIFICATION, OPTICAL COMPONENTS FOR FIRE CONTROL INSTRUMENTS; GENERAL SPECIFICATION GOVERNING THE MANUFACTURE, ASSEMBLY, AND INSPECTION OF, Section 3.6.2
- 5.10.3.5.3 Bonding defects – voids & separation
- MIL-PRF-13830B, PERFORMANCE SPECIFICATION, OPTICAL COMPONENTS FOR FIRE CONTROL INSTRUMENTS; GENERAL SPECIFICATION GOVERNING THE MANUFACTURE, ASSEMBLY, AND INSPECTION OF, Section 3.6.3.1
- 5.10.3.5.4 Dirt (dust or lint) inspection
- MIL-PRF-13830B, PERFORMANCE SPECIFICATION, OPTICAL COMPONENTS FOR FIRE CONTROL INSTRUMENTS; GENERAL

Page 73 of 80

CO_CONFIDENTIAL

CO_CONFIDENTIAL

SPECIFICATION GOVERNING THE MANUFACTURE, ASSEMBLY, AND
INSPECTION OF, Section 3.8.2.5.1

5.10.3.5.5 Inspection for cleanliness

- MIL-PRF-13830B, PERFORMANCE SPECIFICATION, OPTICAL COMPONENTS FOR FIRE CONTROL INSTRUMENTS; GENERAL SPECIFICATION GOVERNING THE MANUFACTURE, ASSEMBLY, AND INSPECTION OF, Section 4.2.10.9
- MIL-F-48616, FILTER (COATINGS), INFRARED INTERFERENCE: GENERAL SPECIFICATION FOR, Section 3.4.1.3

5.10.3.5.6 Scratches inspection

- MIL-C-48497A, COATING, SINGLE OR MULTILAYER, INTERFERENCE: DURABILITY REQUIREMENTS FOR, Section 3.3.5.2.1, 3.3.5.2.2
- MIL-F-48616, FILTER (COATINGS), INFRARED INTERFERENCE: GENERAL SPECIFICATION FOR, Section 3.4.1.2

5.10.3.5.7 Visual inspection method

- MIL-PRF-13830B, PERFORMANCE SPECIFICATION, OPTICAL COMPONENTS FOR FIRE CONTROL INSTRUMENTS; GENERAL SPECIFICATION GOVERNING THE MANUFACTURE, ASSEMBLY, AND INSPECTION OF, Appendix C.4.5.3.1
- MIL-C-48497A, COATING, SINGLE OR MULTILAYER, INTERFERENCE: DURABILITY REQUIREMENTS FOR, Figure 1

5.10.3.6 On-Vehicle Acceptance Test will be performed by Buyer. Technical support including failure analysis, integration and troubleshooting with regards to the

CO_CONFIDENTIAL

CO_CONFIDENTIAL

Vision System hardware shall be provided by the Contractor. The Contractor shall be responsible for its own cost within their scope of supply to rectify the error.

5.10.4 System Verification

5.10.4.1 System Testing Concept

5.10.4.1.1 The Contractor will outline the concept of system testing, starting from the assembly level to the complete system level. All the different testing stages will be identified and described in detail.

5.10.4.1.2 The Contractor will provide the testing setup for each stages of the testing phase. The use of different simulation tools or simulators at different testing phase has to be stated clearly. The capabilities of the simulation tools and simulators requirements at the different testing phase have to be stated clearly.

5.10.5 Acceptance Test Documentation

5.10.5.1 For each of the acceptance test listed in Section 5.10.3.4, the Contractor shall provide the following Acceptance Test Documentation (ATPC and ATP shall be provided as a single document):

- a. Acceptance Test Plans & Criteria (ATPC)
- b. Acceptance Test Procedures (ATP)
- c. Acceptance Test Report (ATR)

5.10.5.2 For each of the Acceptance Tests listed in Section 5.10.3.4, Acceptance Test Plans and Criteria shall be submitted in accordance with the Buyer' schedule.

CO_CONFIDENTIAL

CO_CONFIDENTIAL

5.10.6 Acceptance Test Procedures (ATP)

- 5.10.6.1 For each of the acceptance tests, the Contractor shall submit the procedures in accordance with Buyer' schedule.
- 5.10.6.2 The final ATP shall be submitted in accordance with Buyer' schedule before the conduct of the test.
- 5.10.6.3 The Acceptance Test Procedures shall be developed from the ATPC.
- 5.10.6.4 The Acceptance Test Procedures shall include step-by-step description of how the test shall be conducted, specification data sheets and the test results pass / fail criteria.
- 5.10.6.5 It shall also include a conformance table to indicate whether each measurement meets its specifications.
- 5.10.6.6 The Contractor shall inform Buyer in writing ahead of the date of testing.

5.10.7 Acceptance Tests Reports (ATR) Requirements

- 5.10.7.1 The test report shall include but not limited to the following information:
- a. Updated acceptance test procedures if required
 - b. Complete test results / records / printouts
 - c. Hard copies of measured data
 - d. Discussion of the results
 - e. In case of the test failure, a description of the corrective action taken and repeat test results shall be included.

CO_CONFIDENTIAL

CO_CONFIDENTIAL

5.10.7.2 For each of the acceptance tests, the Contractor shall submit the final report to Buyer in accordance with the Buyer' schedule (unless otherwise specified) from successful completion of the respective test.

5.10.7.3 The Contractor shall be responsible to ensure that proper corrective actions are recommended, implemented and proven effective for defects / faults found during acceptance tests.

5.10.8 General Requirements / Preparation Prior to Tests

5.10.8.1 Prior to each Acceptance Test, the equipment to be tested shall be calibrated and shall be subjected successfully to the approved Acceptance Test Procedure at least once by the Contractor's QA before formal testing begins.

5.10.8.2 Applicable records / results from informal / production testing conducted on the WIU prior to the formal testing shall be made available to Buyer upon request before the formal Acceptance Test is conducted.

5.10.8.3 The Contractor shall be liable to provide all the necessary equipment, logistics and resources for preparation prior to the tests.

5.10.9 Design Review

5.10.9.1 Design and Interface Reviews shall be held to review the design of the Vision System. The Contractor shall demonstrate and verify to Buyer that the design and the system development / system integration approaches met the contract's technical specifications during the design review.

CO_CONFIDENTIAL

Page 77 of 80

CO_CONFIDENTIAL

5.11 Contract Data Requirements List (CDRL)

5.11.1 The Contractor shall propose the schedule for delivery of the following Contract Data Requirements List (CDRL) documents, but not limited to, subject to Buyer's approval.

- a. Software Configuration Management Plan;
- b. Software Quality Assurance Plan;
- c. Software Development Plan;
- d. System/ Subsystem Specification;
- e. Operational Concept Description;
- f. System/ Subsystem Design Description;
- g. Software Requirements Specification;
- h. Interface Requirement Specification(s);
- i. Software Design Description;
- j. Interface Design Description;
- k. Software Test Plan;
- l. Software Test Description;
- m. Software Test Report;
- n. Software Version Description;
- o. Firmware Support Manual(s), if applicable;
- p. Software User Manual, if applicable;
- q. Computer Operation Manual, if applicable;

CO_CONFIDENTIAL

CO_CONFIDENTIAL

- r. Whitebox Test Report;
- s. Code Coverage Analysis Report;
- t. Performance Test Plan;
- u. Performance Test Report;
- v. Software Production Specification;
- w. Preliminary Integration Test (PIT) Plan;
- x. Software Acceptance Test Plan (SWAT);
- y. Installation Control Document;
- z. Interface Requirement Document;
- aa. Interface Design Specification;
- bb. Software Safety Program Plan;
- cc. Software Safety Assessment Report;
- dd. Software Requirements Traceability Matrix;
- ee. EQT Test Plan;
- ff. EQT Test Report;
- gg. EQT Test Procedures;
- hh. EMC Test Plan;
- ii. EMC Test Report;
- jj. EMC Control Plan;
- kk. Security Implementation Plan;
- ll. Secure System Development Plan;
- mm. System Security Compliance Test Plan;

Page 79 of 80

CO_CONFIDENTIAL

CO_CONFIDENTIAL

- nn. System Security Compliance Test Report;
- oo. Software Security Test Plan;
- pp. Software Security Test Report;
- qq. Plan for Anti-Malware management.

5.12 **Integrated Logistics Support (ILS) Requirements**

Refer to Appendix C.

5.13 **Reliability & Maintainability Requirements**

Refer to Appendix D.

5.14 **Quality Assurance**

Refer to Appendix E.

5.15 **Software Development Requirements**

Refer to Appendix F.

5.16 **ARSS Requirements**

Refer to Appendix G.

5.17 **Deliverables and Schedule**

Refer to Appendix I.

CO_CONFIDENTIAL